

PRESTO®

23-quart induction compatible

Pressure Canner

with stainless steel clad base

- Designed for easy, confident home pressure canning. The only method recommended safe for canning meats, vegetables, poultry, and seafood.
- Doubles as a boiling water canner for fruits, jams, jellies, pickles, and salsa.
- Works on gas, electric (coil and smooth-top), and induction ranges.



Estas instrucciones también están disponibles en español.

Para obtener una copia impresa:

- Descargue en formato PDF en www.GoPresto.com/espanol.
- Envíe un correo electrónico a contact@GoPresto.com.
- Llame al 1-800-877-0441, oprima 2 y deje un mensaje.

For more canning information and recipes, visit www.GoPresto.com/content/canning

©2022 National Presto Industries, Inc.
Form 4033-014B

Instructions and Recipes

TABLE OF CONTENTS

Important Safeguards	2	How to Can Foods Using Boiling Water Method	22
Getting Acquainted	2	How to Pressure Cook Foods in Your Pressure Canner	24
Canning Basics	4	Important Safety Information	25
Before Using the Canner for the First Time	5	Helpful Hints for Pressure Cooking	26
How to Pressure Can Foods	6	Pressure Cooking Meat	26
Troubleshooting	8	Pressure Cooking Poultry	30
Care and Maintenance.	9	Pressure Cooking Dry Beans and Peas	31
Canning Fruits.	10	Pressure Cooking Soup and Stock	33
Canning Tomatoes and Tomato Products	13	Pressure Cooking Desserts	34
Pressure Canning Vegetables	15	Recipe Index	36
Pressure Canning Meat, Game, and Poultry	19	Consumer Service Information	37
Pressure Canning Fish and Seafood	20	Warranty	37
Pressure Canning Stock and Soup	21		

This is a  Listed appliance. The following important safeguards are recommended by most portable appliance manufacturers.

IMPORTANT SAFEGUARDS

To reduce the risk of personal injury or property damage, basic safety precautions should always be followed, including the following:

1. Read all instructions. Improper use may result in bodily injury or property damage.
2. Always check the vent pipe before use. Hold cover up to light and look through vent pipe to be certain it is clear.
3. Always check the air vent/cover lock to make sure it moves freely before use.
4. Do not fill pressure canner over $\frac{2}{3}$ full when using for pressure cooking. For soup, grains, and dry beans and peas which expand during cooking, do not fill canner over $\frac{1}{2}$ full. Overfilling may cause a risk of blocking the vent pipe and developing excess pressure. See food preparation instructions.
5. Do not pressure cook applesauce, cranberries, rhubarb, cereals, pasta, split peas, dried soup mixes, or any dry beans and peas which are not listed in the chart on page 32. These foods tend to foam, froth, and sputter and may block the vent pipe, overpressure plug, and air vent/cover lock.
6. This appliance cooks under pressure. Improper use may result in scalding injury. Make certain pressure canner is properly closed before operating; cover handles must be above the body handles. See “HOW TO PRESSURE CAN FOODS” instructions.
7. Do not place the pressure canner or attempt to pressure can or cook in a heated oven.
8. **CAUTION!** Do not overheat or run the canner dry and do not use the canner on too large of an element or on a burner over 12,000 BTU’s. Doing so may soften the canner and cause the bottom to warp which may result in the stainless steel clad base separating from the canner. It may also result in property damage and/or personal injury.
9. Extreme caution must be used when moving a pressure canner containing hot liquids. Do not touch hot surfaces. Use handles or knobs.
10. Do not open canner until internal pressure has been completely reduced, air vent/cover lock has dropped, and no steam escapes when the pressure regulator is removed. See “HOW TO PRESSURE CAN FOODS” instructions.
11. To ensure safe operation and satisfactory performance, replace the overpressure plug every time you replace the sealing ring or sooner if it becomes hard, deformed, cracked, worn, or pitted. It is recommended that the sealing ring and overpressure plug be replaced at least every 3 years. Use only genuine Presto® replacement parts.
12. Close supervision is necessary when the pressure canner is used near children. It is recommended that children not use the pressure canner.
13. When operating pressure is reached, gradually lower the heat to maintain the pressure. If the pressure regulator is allowed to rock vigorously, excess steam will escape, causing more liquid to evaporate. Food will scorch and the canner may go dry, resulting in damage to the canner.
14. Do not use this pressure canner for other than intended use.
15. Do not use this pressure canner for pressure frying with oil.

SAVE THESE INSTRUCTIONS

THIS APPLIANCE IS FOR HOUSEHOLD USE ONLY.

GETTING ACQUAINTED

Your canner is a special, large capacity pressure vessel designed for home canning a wide variety of fruits, vegetables, meats, poultry, fish, and seafood.

The canner uses pressure to achieve the high temperatures required for safely processing foods while canning. The United States Department of Agriculture (USDA) recommends the pressure canner as the only safe method for canning low-acid foods—vegetables, meats, poultry, fish, and seafood.

The canner may also be used to pressure cook many of your favorite foods in larger quantities than can be prepared in a conventional size pressure cooker. Pressure cooking saves time and energy by cooking foods three to ten times faster than ordinary methods. Pressure cooking preserves flavor and nutrients and tenderizes tougher cuts of meat. Information for pressure cooking begins on page 24.

Become familiar with the various parts shown on page 3. Do not attempt to use your pressure canner before reading the instructions on pages 6 through 8.

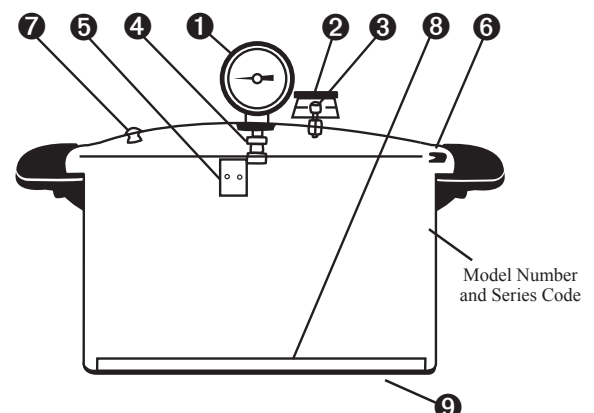

1. PRESSURE DIAL GAUGE

The pressure dial gauge registers pressure in pounds per square inch, or PSI. The pointer moves around the dial indicating the pressure within the unit. Pressure can be controlled and maintained by adjusting the heat setting on your stove.

NOTE: The pressure dial gauge can be found in the foam filler of the carton.

2. PRESSURE REGULATOR

The pressure regulator acts as a safety device to prevent pressure in excess of 15 pounds from building in the canner. Pressure readings are registered only on the pressure dial gauge.

NOTE: The pressure regulator can be found in the top foam filler of the carton. It is in a bag identified with the words “Pressure Regulator Enclosed.”

3. VENT PIPE

The vent pipe is the primary pressure relief valve and will release pressure in excess of 15 pounds. The pressure regulator sits loosely on the vent pipe.

4. AIR VENT/COVER LOCK

The air vent/cover lock automatically vents or exhausts air from the canner and acts as a visual indication of pressure in the canner. The small gasket must be in place for the air vent/cover lock to seal completely.

5. LOCKING BRACKET

The locking bracket on the inside of the canner body engages with the air vent/cover lock to prevent the cover from being opened when there is pressure in the unit.

6. SEALING RING

The sealing ring fits into the canner cover and forms a pressure-tight seal between the cover and body during canning and cooking.

7. OVERPRESSURE PLUG

The black, rubber overpressure plug is located in the canner cover. It will automatically pop out and release steam in case the vent pipe becomes blocked and pressure cannot be released normally through the vent pipe.

8. CANNING-COOKING RACK

The canning-cooking rack is placed in the bottom of the canner to hold jars off the bottom of the unit while canning. Always use the rack when canning. When cooking, the rack is used for steaming foods. It can also be used to hold foods such as vegetables out of the cooking liquid, allowing several foods to be cooked at the same time without an intermingling of flavors. When it is desirable to blend flavors, do not use the canning-cooking rack.

9. STAINLESS STEEL CLAD BASE

The pressure canner is constructed of heavy-gauge aluminum with a stainless steel clad base for fast, even heating. It is specially designed for induction ranges. It also works on gas and electric coil and smooth-top ranges.*

REPLACEMENT PARTS

Use only genuine Presto® replacement parts. These parts are available at most hardware stores or they can be ordered directly from Presto; see “CONSUMER SERVICE INFORMATION” on page 37. When ordering parts, please specify the seven digit model number found stamped on the side of the canner body.

CAUTION! Use only the cover that came with the canner when new. Using a different cover may prevent the locking mechanisms from operating properly and may result in property damage and/or personal injury.

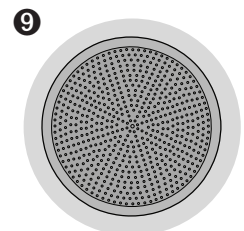
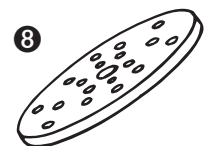
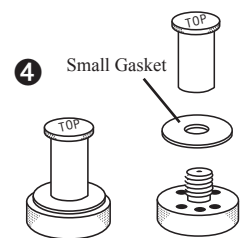
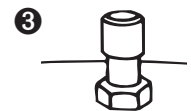
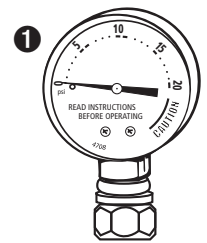

*Portable induction cooktops or other portable burners may not be suitable for canning. They may not have enough wattage to pressurize a fully loaded canner and/or they may not be able to support the weight of a fully loaded canner. Refer to the owner's manual for your portable heat source for weight restrictions and other information. The canner itself weighs 17 pounds when it contains 3 quarts of water. An empty quart jar weighs approximately 14 ounces and an empty pint jar weighs approximately 9 ounces.

CANNING BASICS

INTRODUCTION

The key to successful canning is to understand the acidity and spoilage factor of the food you wish to can, as well as the acceptable canning methods to process those foods. There are invisible microorganisms present all around us. Fruits, vegetables, and meat contain these microorganisms naturally and yet they are not a problem unless food is left to sit for extended periods of time, causing food spoilage. This is nature's way of telling us when food is no longer fit to eat.

There are four basic agents of food spoilage—enzymes, mold, yeast, and bacteria. Canning interrupts the natural spoilage cycle so food can be preserved safely. Molds, yeast, and enzymes are destroyed at temperatures below 212°F, the temperature at which water boils (except in mountainous regions). Therefore, boiling water processing is sufficient to destroy those agents.

Foods naturally high in acid and acidified foods having a pH of 4.6 or less may be safely processed using the boiling water method.

Step-by-step instructions for the boiling water method begin on page 22.

Bacteria, however, are not as easily destroyed. The bacteria *Clostridium botulinum* produces a spore that makes a poisonous toxin which causes botulism. This spore is not destroyed at 212°F. In addition, the bacteria thrive on low-acid foods in the absence of air. According to the USDA, pressure canning is the only safe method of processing low-acid foods (vegetables, meats, poultry, fish, and seafood).

In pressure canning, some of the water in the pressure canner is converted to steam, which creates pressure within the canner. As pressure increases, temperature increases: 5 pounds pressure—228°F, 10 pounds pressure—240°F, 15 pounds pressure—250°F. This pressurized heat destroys the potentially harmful bacterial spores. **Step-by-step instructions for the pressure canning method begin on page 6.**

As jars cool after processing (by either the boiling water or pressure canning method) a vacuum is formed, sealing food within and preventing any new microorganisms from entering and spoiling the foods.

BEFORE BEGINNING

Selecting a Recipe

To produce home canned food that is safe for storage at room temperature, it is necessary to use a tested canning recipe. Recipes that have been handed down through the years or those found on the web are oftentimes unreliable and usually do not include scientifically tested processing procedures that are vital to a successful and safe canning project. Canning information published prior to 1994 may be incorrect and could pose a serious health risk. A tested canning recipe has been evaluated to determine the accurate processing method (boiling water canning or pressure canning) as well as the processing time.

Always choose recipes from a reliable resource, such as the National Center for Home Food Preservation (nchfp.uga.edu), your local Cooperative Extension Service, or this instruction book.

Do NOT can leftovers; it is not safe.

Selecting Jars

Glass home canning jars, sometimes referred to as Mason jars, are the only jars recommended for safe home canning. They are available in standard sizes (half-pint, pint, and quart jars) and will withstand the heat of a pressure canner, time after time. The diameter of Mason jars may vary from one manufacturer to another.

Before filling Mason jars, test load your canner. It may be necessary to double-deck pint and half-pint jars to reach the maximum capacity of your canner, as indicated in the chart to the right. To double-deck, stagger the jars by placing one jar on top of two. However, if using the boiling water method, do not double-deck jars. Jars may touch. The canning rack which accompanied your pressure canner must be placed on the bottom of the canner to prevent jar breakage. Although it is not necessary to use a rack between layers of jars, if you wish to do so, a rack can be ordered from the Presto Consumer Service Department. See page 37.

Maximum Mason Jar Capacity	
Regular jars	Wide mouth jars
26 half-pints*	16 half-pints*
20 pints*	16 pints*
7 quarts	7 quarts

*It will be necessary to double-deck jars to achieve the maximum capacity; see information above.

For boiling water method, do not double-deck jars.

Canning Lids and Bands

The two-piece vacuum cap (lid and band) is the recommended closure for home canning. It consists of a flat metal lid with a sealing compound on the outer edge and a separate metal screw band that secures the lid during processing. The flat lid is for one use only while the bands can be used repeatedly if they remain in good condition. Do not use dented or rusty bands. Use only jars, lids, and screw bands in perfect condition so an airtight seal may be obtained.

Measuring Headspace

Headspace is the air space between the top of the food or its liquid and the lid. Leaving too much headspace can result in underprocessing because it may take too long to release the air from the jar. Leaving too little headspace will trap food between the jar and the lid and may result in an inadequate seal. As a general rule, allow ¼-inch headspace for jams and jellies; ½-inch headspace for fruits and tomatoes; 1-inch for vegetables, meats, and seafood; and 1¼-inch for poultry. All recipes will indicate the amount of headspace necessary for the food being canned.

Removing Air Bubbles

After food has been packed in jars, any air bubbles must be removed. Trapped air bubbles may rise to the top during processing, causing too much headspace. Work quickly to remove air bubbles that have become trapped between pieces of food by moving a clean, nonmetal spatula around the jar between the food and side of the jar.

Preparing Jar Rims and Adjusting Lids

Immediately wipe the jar rims with a clean, damp cloth to remove any residue. Any food particles, such as seeds, grease, or syrup, on the rim of the jar may prevent the jar from sealing. Place the flat lid on the rim of the jar, making sure the sealing compound is touching the glass. Position a band over the lid and, using fingertips, screw it onto the jar just until resistance is met (fingertip tight). Do not overtighten as air must release from the jars during processing and cooling.

Other Special Canning Tips

To prevent water stains on jars, add 2 tablespoons of white vinegar to water in canner.

AFTER PROCESSING

Cooling Jars

After processing, remove jars to a dry towel on countertop away from drafts. Leave 1 to 2 inches of space between jars to allow for even cooling. Do not retighten bands. Do not invert jars or cover with a cloth. Check seals no earlier than 12 hours, but no later than 24 hours.

Bubbles often appear in the jar after removal from the canner because food is still boiling in the jar. Ordinarily bubbles do not appear once the product has been allowed to thoroughly cool.

Testing Seals and Storing Canned Food

After jars have cooled, test the jar lids to be sure a vacuum seal has formed. Press down on the center of the flat lid to determine if it is concave (stays down when pressed). Remove the screw band and gently try to lift the lid with your fingertips. If the center does not flex up and down and you cannot lift the lid off, the lid has a good seal. Wipe off any food residue from jars and lids. Date and label jars. Store in a cool, dark, and dry place.

If a jar does not seal, the food can be refrigerated and used within 3 days. Other options include freezing the food or reprocessing for the full amount of time per the canning recipe. If choosing to reprocess, remove the lids and reheat the food and/or liquid. Pack food into clean, heated jars. Remove air bubbles and clean jar rims. Position new lids on jars and secure with bands. **If more than 24 hours have elapsed since you completed canning, and the seal is faulty, the food is no longer safe. Discard at once.**

Detecting Spoilage

If up-to-date instructions and processing times and pressures are followed carefully, spoilage is uncommon. However, it is still recommended to check for signs of spoilage before tasting any canned food. Check for a broken seal, gassiness when opening, mold, sliminess, cloudiness, or unpleasant odors. If any of these signs are present, discard the food. As a safeguard against using canned low-acid and tomato products which may be affected with spoilage that is not readily detected, boil food 10 minutes for altitudes up to 1,000 feet above sea level. Extend the boiling time by 1 minute for each 1,000 foot increase in altitude. Many times odors that cannot be detected in the cold product will become evident by this method. If, after boiling, food does not smell or look right, **discard it without tasting.**

BEFORE USING THE CANNER FOR THE FIRST TIME

1. Remove the sealing ring by simply pulling it from the sealing ring groove.
2. Wash the cover, body, and sealing ring with hot, soapy water to remove any manufacturing oils. Rinse all parts with warm water and dry. Dishwasher use for aluminum canners in **not** recommended, as discoloration will occur.
3. Replace the sealing ring in the sealing ring groove, making certain to fit the ring under the stop tab located on the inside rim of the cover (Fig. A).
4. The sealing ring is prelubricated. The cover should open and close easily when following step 10, page 7.

If necessary, to help make the cover easier to open and close, a very light coating of vegetable oil may be applied to the sealing ring and underside of the body lugs (Fig. A).

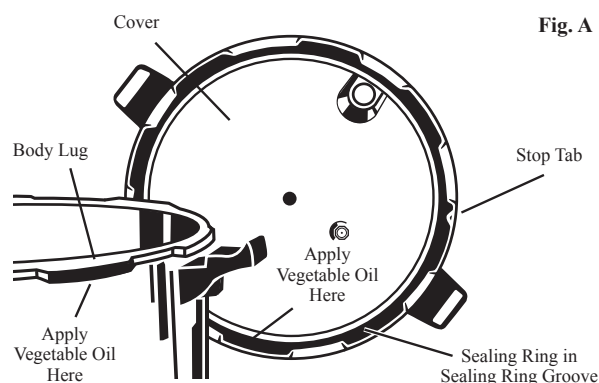

5. Check the air vent/cover lock in the canner cover to be sure the two pieces are screwed together securely. If loose, tighten with fingers until a point of resistance is met (fingertip tight). See page 10.
6. Attach the dial gauge to the canner cover following the steps below. It is suggested you sit down to perform the installation.
 - a. Hold the gauge in your hand with the threaded stem pointing up and remove the nut and metal washer from the stem. The white gasket should remain on the stem. Continue to hold the gauge with the stem and gasket pointing up.
 - b. With your other hand, grasp the cover, turn it upside down, and position the center hole over the gauge stem and gasket. Push the threaded stem up through the hole until the metal base is against the cover.
 - c. While holding the gauge in place, push the gasket down so it rests within the cover hole. Then position the metal washer and nut on the threaded stem of the gauge (Fig. B). Tighten the nut until fingertip tight. Overtightening may damage the gasket.

Note: The gasket will not be visible from the top or bottom of the canner cover, but it will be embedded in the cover hole so the canner will seal properly.

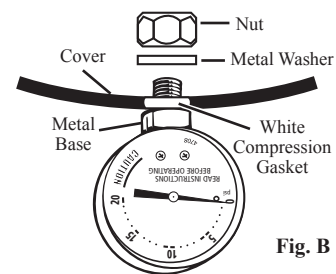

IMPORTANT: The dial gauge is a delicate instrument which must be handled with care. Do not submerge cover or let gauge come in contact with any liquid. Do not store the dial gauge at temperatures below freezing.

Perform “WATER TEST” before first use.

To help yourself understand the operation of the pressure canner, practice first with water only. Follow the step-by-step instructions for pressure canning, beginning with step 6 page 7. Use 3 quarts of hot water; do not use jars or food.

HOW TO PRESSURE CAN FOODS

IMPORTANT: Do not attempt to use your canner before carefully reading these instructions.

For actual usage of the canner, follow the step-by-step instructions for pressure canning starting below and prepare food according to the processing procedures in the specific recipe.

1. Be sure your canner is thoroughly cleaned and working properly.
 - Before each canning season, have the dial gauge checked for accuracy; see page 9.
 - Check the sealing ring and overpressure plug. Replace both parts at least every 3 years, but immediately replace them when they become hard, deformed, cracked, worn, pitted, or unusually soft. Make sure the overpressure plug is seated properly in the cover (Fig. K, page 9)
 - Check the white gasket on the air vent/cover lock. It should be intact, without cracks or tears. Be sure the two metal parts of the air vent/cover lock are securely fastened (Fig. L, page 10).
2. If canning on an electric smooth-top or induction range, refer to instructions for canning in the owner’s manual for your range. Always clean the stovetop with a cooktop polishing cream, according to the range manufacturer’s instructions, before and after canner use. In addition, to avoid scratching the ceramic glass surface of the smooth-top or induction range, check the bottom of the canner to be sure it is clean and free of debris and does not have any nicks or scratches.
3. Check Mason jars for nicks, cracks, and sharp edges. Check screw bands for dents or rust. Use only jars, lids, and screw bands in perfect condition so an airtight seal may be obtained.

Wash and rinse jars, lids, and screw bands. Pour hot water into jars and set aside until needed. Follow closure manufacturer’s directions for preparing lids.
4. Select fresh, firm food. Sort food according to size. Clean food thoroughly. Prepare according to specific recipe. Fill hot jars promptly with food and liquid to recommended level.

Allow ½-inch headspace for fruits and tomatoes. Most vegetables and meats require 1-inch headspace due to expansion during processing.

Work out air bubbles with a clean nonmetal spatula. Wipe sealing edge clean with a damp cloth. Adjust screw bands according to closure manufacturer’s directions.
5. Place the canning rack in the canner. Always use the canning rack as jars may break if set directly on the bottom of the canner.

- Pour **3 quarts of hot water** in the canner (Fig. C). For hot packed foods, the water can be heated to 180°F, or not quite boiling.

Note: 3 quarts of water are needed regardless of how many jars are being canned.

When processing for times in excess of 100 minutes (1 hour 40 minutes), always add an additional quart of water.

To prevent water stains on the jars, add 2 tablespoons of white vinegar to the water in the canner.

- Place the jars on the canning rack immediately after each jar is filled.
- Hold the cover up to the light and look through the vent pipe (Fig. D) to be certain it is clear before placing the cover on the canner. If it is clear, proceed to step 9. If it is blocked, clean the vent pipe and vent pipe nut with a small brush or pipe cleaner (Fig. E and Fig. F).
- Make sure the two pieces of the air vent/cover lock are screwed together (fingertip tight).
- Place the cover on the canner, aligning the **V** mark on the cover with the inverted **V** mark on the body handle (Fig. G). Press down on the cover handles to compress the sealing ring and turn the cover in the direction indicated to close (clockwise) until the cover handles are above the body handles. Do not rotate the cover beyond this point.
- Position the canner on a level burner and range only. Use on a tilted burner or range may interfere with the operation of the pressure regulator. For electric coil, smooth-top, and induction ranges, use the element that most closely matches the 9-inch diameter of the canner bottom. This is the portion of the canner bottom which comes in contact with the element. Do not use on any outdoor LP gas burner or a gas range over 12,000 BTU's.

CAUTION! Do NOT overheat the canner, allow it to run dry, use on too large of an element, or use on a burner over 12,000 BTU's. Doing so may soften the canner and cause the bottom to warp which may result in the stainless steel clad base separating from the canner. It may also result in property damage and/or personal injury.

Using a high setting, heat the pressure canner until a steady flow of steam can be seen, heard, or felt coming from the vent pipe (Fig. H). Exhaust air from the canner for 10 minutes by allowing steam to flow from the vent pipe. Reduce the heat, if necessary, to maintain a steady, moderate flow of steam.

- Place the pressure regulator on the vent pipe. If the heat was reduced for exhausting, adjust it back to a high setting and heat the canner. As pressure develops in the canner, the air vent/cover lock will lift and lock the cover on the canner body.

The air vent/cover lock is a visual indicator of the presence of pressure. When it is in the up position, there is pressure in the canner; when it is in the down position, there is no pressure in the canner (Fig. I). Also, as pressure builds, the pointer of the gauge should move across the face. If the pointer does not move and the regulator begins rocking, see step 13 to process at 15 pounds pressure. Replace the gauge before using the canner again.

- Continue heating until the pressure dial gauge registers the correct pressure. Adjust the heat to maintain the correct pressure on the dial gauge for the duration of the processing time.

If you are canning at 15 pounds pressure, the pressure regulator may begin to rock before the dial gauge registers it, indicating 15 pounds pressure has been reached inside the canner. Should this happen, ignore the dial gauge and lower the heat to maintain a continuous, slow rocking motion of the pressure regulator for the duration of the processing time. To see a video of a regulator rocking, visit www.GoPresto.com/ppc/rocking.

- Processing time begins when the correct pressure has been reached. If pressure drops below the desired setting, it will be necessary to bring the pressure to the correct setting and begin processing countdown from the beginning for the full amount of time.

Helpful Hint: To more easily maintain pressure, it may be beneficial to reduce the heat when the pressure dial gauge registers 1½ to 2 pounds less than the desired pressure. However, do not begin the processing countdown until the correct pressure is reached.

- At the end of the processing time, turn the burner off and, if possible, remove the canner from the heat source. Allow the canner to cool down naturally.

Fig. C
3-quart Water Line (lowest mark in canner)

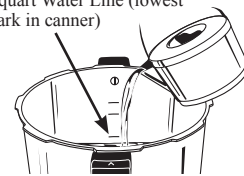

Fig. D

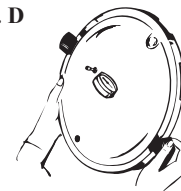

Fig. E

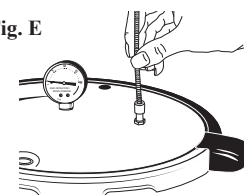
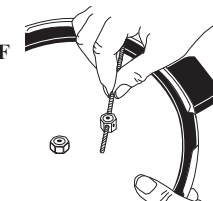

Fig. F



Align the **V** mark on the cover with the inverted **V** mark on the body handle.

Fig. G



Fig. H

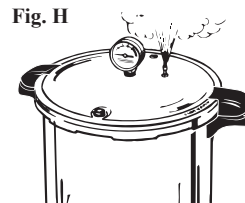

Fig. I UNLOCKED



Air Vent/Cover Lock in DOWN Position. No Pressure in Unit.

LOCKED



Air Vent/Cover Lock in UP Position. Pressure in Unit.

NOTICE: Lift the pressure canner to remove it from the burner. Sliding any cookware may leave scratches on stovetops. **Note:** If the canner is too heavy to move easily, it is also okay to leave it in place after turning off the burner. It is better to do this than let the jars inside tilt or tip over.

Fig. J

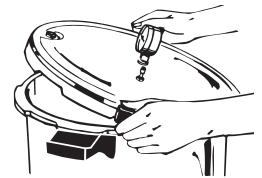

16. Let pressure drop of its own accord. **Do not attempt to speed the cooling of the canner, which can cause jar breakage, liquid loss from the jars, and other problems.** Pressure is completely reduced when the air vent/cover lock and overpressure plug have dropped and no steam escapes when the pressure regulator is lifted. Do not use the pressure dial gauge as an indicator for when pressure is completely reduced.

17. **Do not remove the pressure regulator until pressure is completely reduced and the air vent/cover lock has dropped.** When pressure has been completely reduced, remove the pressure regulator from the vent pipe and let the canner cool for 10 minutes. Always remove the pressure regulator before opening the cover.

18. To remove the cover, turn it counterclockwise until it hits the stop tab. The cover handles will be beyond the body handles. Lift the canner cover toward you to keep steam away from you (Fig. J).

CAUTION! If the cover seems to stick or is hard to turn, **do not force it open.** Sticking may indicate that there is still pressure inside the canner. If in doubt about pressure being completely reduced, let the canner stand until cool before removing the cover.

19. Using a jar lifter, remove the jars by lifting them straight up. Be careful not to tilt them, which causes liquid to siphon from jars. Place jars upright on a board or dry towel, away from drafts. Do not retighten bands. Allow jars to cool naturally. Check seals no earlier than 12 hours, but no later than 24 hours. See page 5 for “After Processing” information.

NOTICE: When processing consecutive batches, be sure to check the water level in the canner between batches. Add water, if necessary, to keep water at the 3-quart mark (Fig. C, page 7).

20. When canning is complete, allow the canner to cool completely before cleaning.

Canner Storage: Store the canner in a dry place at temperatures above freezing with the cover inverted on the canner body. Exposure to temperatures below freezing can damage the gauge. Storing the canner with the cover locked on may cause unpleasant odors and deform the sealing ring. The canner must be completely dry before storing.

TROUBLESHOOTING

- ◆ Bubbles often appear in the jar after removal from the canner because food is still boiling in the jar. Ordinarily bubbles do not appear once the product has been allowed to thoroughly cool.
- ◆ Jar breakage during processing is caused by: (1) packing jars too solidly or overfilling; (2) weakened, nicked, or chipped jars; (3) jars touching bottom of canner; (4) failure to tighten screw bands according to manufacturer’s directions; (5) use of jars other than Mason jars.
- ◆ Liquid lost from jars during processing is caused by: (1) packing jars too solidly or overfilling; (2) insufficient exhaust period; (3) air was exhausted too vigorously during the 10-minute venting period; (4) variation or sudden reduction of pressure in the canner; (5) failure to tighten screw bands according to the manufacturer’s directions.

If liquid is lost during processing, do not open jar to replace liquid. Loss of liquid will not cause spoilage, but food above the liquid will discolor. If at least half of the liquid is gone, place the jar in the refrigerator and use the food within 3 days.

- ◆ Flat sour, a type of food spoilage, is caused by canning overripe food, allowing precooked food to stand in the jar too long before processing, or keeping the jars in the canner too long after processing. It may be prevented by using fresh food; by properly processing, cooling, and storing food; and by removing jars from the canner promptly after processing. Flat sour shows no indication of spoilage until the jar is opened. Discard the contents.
- ◆ Food spoilage or jars not sealing is caused by: (1) failure to follow exact timetables and recipes; (2) failure to wipe sealing edge of jar clean before placing lid on jar; (3) having foods, seeds, or grease lodged between lid and jar; (4) using jars which are nicked, cracked, or have sharp sealing edges; (5) failure to tighten screw bands according to manufacturer’s directions; (6) turning jars upside down while jars are cooling and sealing.

If a jar does not seal, refrigerate it and use the food within 3 days. Otherwise, reprocess or freeze the food within 24 hours. Freeze or repack using new lids. Reprocess for the full recommended processing time.

- ◆ Mold can form only in the presence of air. Therefore, jars are not sealed if mold is present. Discard contents.
- ◆ The black deposit sometimes found on the underside of a lid is caused by tannins in the food or hydrogen sulfide which is liberated from the food by the heat of processing. This does not indicate spoilage.
- ◆ The loss of color from beets during canning is usually due to the variety of beets used. Two varieties that retain color well are Ruby Queen and Detroit Red. To reduce bleeding of color, precook beets with entire root and 1 to 2 inches of stem. Remove stem and root after precooking.
- ◆ For more information, visit www.GoPresto.com/content/canning.

CARE AND MAINTENANCE

Canner Body

- It is normal for the inside of the canner to discolor. This discoloration, which is not harmful, is a result of the various minerals in water and foods interacting with the aluminum of the canner. To remove this discoloration, use a solution of 1 tablespoon cream of tartar for every 1 quart of water. Pour enough solution into the canner to cover the discoloration, making sure the canner is not filled more than $\frac{2}{3}$ full. Close the cover securely, place the pressure regulator on the vent pipe, and heat until the pressure regulator begins to rock. Remove canner from heat and allow it to cool to room temperature. Remove the regulator, open the canner, and empty the contents. Scour thoroughly with a steel wool soap pad; wash, rinse, and thoroughly dry.
- Pitting is caused by the interaction of aluminum with other metals in the presence of moisture. To minimize pitting, wash, rinse, and dry the canner body thoroughly after every use. At least once a year, scour the inside of the canner body with an abrasive cleanser, such as Cameo* Aluminum & Stainless Steel Cleaner. Always store the canner in a dry area.
- Do not leave an empty canner on a heated burner or allow the canner to boil dry. This can cause warping of the canner bottom and may result in the stainless steel clad base separating from the canner. This can also cause damage to the stovetop.
- Do not strike the rim of the canner body with any metal utensil as this will cause nicks which may damage the rim and allow steam to escape.
- Do not pour water into a dry, overheated canner as this may crack the metal.
- If the canner body or cover handles become loose, tighten them with a screwdriver.

Pressure Dial Gauge

- The pressure dial gauge is a delicate instrument and must be handled with care. Do not submerge the pressure dial gauge, allow it to come into contact with liquid, or subject it to freezing temperatures.
- The pressure dial gauge needs to be checked for accuracy prior to each canning season **and** if any of the following conditions exist: cover has been submerged in water or dropped, parts are rusty, pointer is not in the “0” block, or if you believe the gauge may not be accurate. The gauge can usually be checked at your local county extension office. If you are unable to have your gauge checked locally, carefully remove it, securely wrap it, and send it to the Presto Consumer Service Department; see page 37. An accurate gauge is necessary to help prevent food spoilage, possible food poisoning, and avoid potential damage to the canner.

Sealing Ring and Overpressure Plug

- Each time the canner is washed, remove the sealing ring and wash it in warm, soapy water; rinse, dry, and replace it in cover.
 - Before replacing the sealing ring, clean the sealing ring groove with a brush, if necessary.
 - The sealing ring and overpressure plug should be replaced at least every 3 years or sooner if the sealing ring becomes hard, deformed, cracked, worn, pitted, or if the canner is difficult to open or close.
- CAUTION!** Failure to replace the sealing ring and overpressure plug could result in bodily injury or property damage. Use only genuine Presto® replacement parts.
- Exposure of the sealing ring and overpressure plug to direct high heat, such as a hot burner or stovetop, will cause the sealing ring and overpressure plug to deteriorate rapidly. If this occurs, replace these parts.
 - To clean or replace the overpressure plug, push it out of its opening from the top of the cover. After cleaning it, or when replacing it, reinsert the plug by pushing the domed side into the opening from the underside of the cover, until the bottom edge is fully and evenly seated against the underside of the cover. When properly installed, the word (TOP) will be visible on the overpressure plug when viewed from the outside of the cover (Fig. K).
 - If the overpressure plug is ever forced out of the cover due to excess pressure while cooking or canning, it is important to call the Presto Consumer Service Department at 1-800-877-0441 for assistance in determining why this happened. **Do not attempt to use the released overpressure plug.**

Air Vent/Cover Lock

- To remove the air vent/cover lock for occasional cleaning or for replacing the small gasket, grasp and securely hold the cup portion on the underside of the cover with your fingers (Fig. L). Using the fingers of your other hand, turn the pin portion of the air vent/cover lock on the top side of the cover counterclockwise until the pin is free of the cup portion. Lift the pin out of the cover and remove the cup from under the cover.

Carefully pull the small gasket off the threaded shaft on the cup portion.

Wash all parts in warm, soapy water. Use a soft cloth or small nylon brush to clean the cover hole.

Fig. K

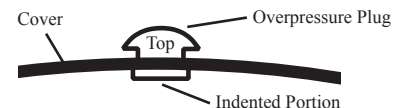

*Cameo is a registered trademark of Armaly Sponge Company. Presto is not affiliated with this Company.

- To reassemble the air vent/cover lock, place the small gasket over the threaded shaft of the cup portion. Reinsert the cup portion by pushing the threaded shaft through the air vent/cover lock opening from the underside of the cover (Fig. L).

Screw the pin portion clockwise onto the threaded shaft until it is fingertip tight. Do not use a wrench to tighten the air vent/cover lock. Overtightening may cause the rubber gasket to wrinkle, which will prevent the canner from sealing.

When properly installed, the word (TOP) will be visible on the air vent/cover lock when viewing the outside of the cover (Fig. I, page 7). Periodically check to make sure these two pieces are tight.

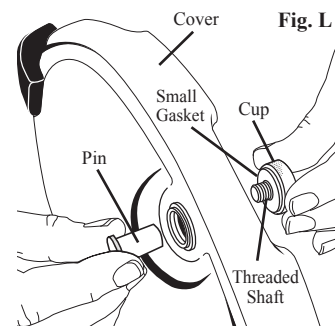

Vent Pipe

- Periodically check the vent pipe nut for looseness. Retighten, if necessary, using a $\frac{7}{16}$ " wrench.

Steam Leakage

If the canner begins to leak moisture or if steam develops during use, check the following possible causes:

- Leakage between the cover and body is usually caused by shrinkage of the sealing ring after prolonged use. Replace both the sealing ring and overpressure plug.
- A slight amount of leakage around the air vent/cover lock is normal when canning or cooking first begins. If leakage continues, the cover handles may not be fully aligned with the body handles (see step 10, page 7). Therefore, the air vent/cover lock cannot engage.

Do not operate your pressure canner with continual leakage. If the preceding steps do not correct the problem, contact the Presto Consumer Service Department. See page 37 for contact information.

CANNING FRUITS

Fruits may be safely processed using the pressure canning method (pages 6 through 8) or the boiling water method (pages 22).

Maintaining Color

Select firm, fully-ripened but not soft fruit. Do not can overripe foods. Some fruit (apples, apricots, nectarines, peaches, and pears) tends to darken while being prepared for canning.

To prevent darkening, place the fruit in a solution of 3 grams (3,000 milligrams) ascorbic acid to 1 gallon of cold water. Ascorbic acid is available in different forms:

Pure Powdered Form: Use 1 teaspoon of pure powder, which weighs about 3 grams, per gallon of water.

Vitamin C Tablets: Buy 500 milligram tablets. Crush and dissolve 6 tablets per gallon of water.

Commercially Prepared Mixes of Ascorbic and Citric Acid: Available under different brand names. Use according to manufacturer's directions found on the package.

Canning Liquids

Although fruit has better color, shape, and flavor when it is canned with syrup, it may be canned in juices (such as apple, white grape, or pineapple) or water as well.

White sugar is preferable to brown sugar for canning. Light corn syrup or honey may be used to replace up to one-half the sugar. If you wish to use sugar substitutes, follow the package instructions.

The amount of sugar desirable to use in preparing syrups will depend upon the tartness of the fruit and on family preference. It should be remembered that fruit, when heated, releases some of its juices which will dilute the syrup in proportion to the juiciness of the fruit.

Use the syrup chart below as a guideline for preparing the syrup needed for your canning recipe. The syrup recipe may be doubled or tripled depending on the packing method and amount of fruit being canned at one time.

SYRUPS FOR CANNING FRUITS			
Combine sugar and water in a large pot. Bring to a boil and keep syrup hot while preparing fruit. Use as directed in recipe.			
Syrup	Sugar	Water	Yield
Very Light	$\frac{1}{2}$ cup	4 cups	$4\frac{1}{2}$ cups
Light	1 cup	4 cups	$4\frac{3}{4}$ cups
Medium	$1\frac{3}{4}$ cups	4 cups	5 cups
Heavy	$2\frac{3}{4}$ cups	4 cups	$5\frac{1}{2}$ cups

Altitude Adjustments

When **pressure canning** at altitudes of 2,000 feet or below or **boiling water canning** at altitudes of 1,000 feet or below, process according to specific recipe. When canning at higher altitudes, process according to the following charts.

Altitude Chart for Pressure Canning Fruits

Altitude	Pounds Pressure
2,001–4,000 ft.	7 pounds
4,001–6,000 ft.	8 pounds
6,001–8,000 ft.	9 pounds

Altitude Chart for Boiling Water Canning Fruits

Altitude	Increase Processing Time
1,001–3,000 ft.	5 minutes
3,001–6,000 ft.	10 minutes
6,001–8,000 ft.	15 minutes

CANNING RECIPES: FRUITS

APPLES

Wash, peel, and core apples. Cut into ½-inch slices. Place apples in an ascorbic acid solution (page 10) to prevent darkening during preparation. Drain well.

Hot Pack: Add apples and syrup (page 10), juice, or water to a large pot and bring to a boil. Boil for 5 minutes, stirring occasionally to prevent scorching. Pack hot apples in hot jars, leaving ½-inch headspace. Cover apples with hot syrup, juice, or water, leaving ½-inch headspace. Remove air bubbles. Clean jar rims. Position lids and secure with bands.

Pressure canning: Process at 6 pounds pressure, pints and quarts 8 minutes. For processing above 2,000 feet altitude, see chart above for recommended pounds pressure.

Boiling water canning: Process pints and quarts 20 minutes. For processing above 1,000 feet altitude, see chart above for recommended time.

APPLESAUCE

Wash, peel, core, and slice apples. If desired, place apple slices into ascorbic acid solution (page 10) to prevent darkening. Drain well. Place slices in a large pot. Add ½ cup water. Heat quickly until apples are tender, stirring occasionally to prevent scorching. Press through food mill or sieve. (If chunk style sauce is preferred, omit this step.) If desired, sweeten to taste. Reheat sauce to boiling. Pack into hot jars, leaving ½-inch headspace. Remove air bubbles. Clean jar rims. Position lids and secure with bands.

Pressure canning: Process at 6 pounds pressure, pints 8 minutes and quarts 10 minutes. For processing above 2,000 feet altitude, see chart above for recommended pounds pressure.

Boiling water canning: Process pints 15 minutes and quarts 20 minutes. For processing above 1,000 feet altitude, see chart above for recommended time.

APRICOTS

Wash well-ripened, firm apricots. If peeled apricots are desired, dip 1 minute in boiling water, then in cold water and peel. Cut apricots in halves and remove pits. Place apricots in an ascorbic acid solution (page 10) to prevent darkening during preparation. Drain well.

Hot Pack: Add apricots and syrup (page 10), juice, or water to a large pot and bring to a boil. Pack hot apricots, cut side down, in hot jars, leaving ½-inch headspace. Cover with hot syrup, juice, or water, leaving ½-inch headspace. Remove air bubbles. Clean jar rims. Position lids and secure with bands.

Raw Pack: Pack raw apricots, cut side down, in hot jars, leaving ½-inch headspace. Cover with hot syrup, juice, or water, leaving ½-inch headspace. Remove air bubbles. Clean jar rims. Position lids and secure with bands.

Pressure canning (hot and raw pack): Process at 6 pounds pressure, pints and quarts 10 minutes. For processing above 2,000 feet altitude, see chart above for recommended pounds pressure.

Boiling water canning:

Hot Pack: Process pints 20 minutes and quarts 25 minutes. For processing above 1,000 feet altitude, see chart above for recommended time.

Raw Pack: Process pints 25 minutes and quarts 30 minutes. For processing above 1,000 feet altitude, see chart above for recommended time.

BERRIES (except strawberries and elderberries)

Choose ripe, sweet berries with uniform color. Wash 1 or 2 quarts of berries at a time. Drain, cap, and stem if necessary.

Hot Pack: Use this method for firmer berries such as blueberries, currants, gooseberries, and huckleberries. Heat berries in a large pot with boiling water for 30 seconds and drain. Add ½ cup hot syrup (page 10), juice, or water to hot jars. Pack hot berries into jars, leaving ½-inch headspace. Cover with hot syrup, juice, or water, leaving ½-inch headspace. Remove air bubbles. Clean jar rims. Position lids and secure with bands.

Pressure canning: Process at 6 pounds pressure, pints and quarts 8 minutes. For processing above 2,000 feet altitude, see page 11 for recommended pounds pressure.

Boiling water canning: Process pints and quarts 15 minutes. For processing above 1,000 feet altitude, see page 11 for recommended time.

Raw Pack: Use this method for softer berries such as raspberries and blackberries. Add ½ cup hot syrup (page 10), juice, or water to hot jars. Pack raw berries into jars, leaving ½-inch headspace. Gently shake jars while filling to pack firmly without crushing berries. Cover with hot syrup, juice, or water, leaving ½-inch headspace. Remove air bubbles. Clean jar rims. Position lids and secure with bands.

Pressure canning: Process at 6 pounds pressure, pints 8 minutes and quarts 10 minutes. For processing above 2,000 feet altitude, see page 11 for recommended pounds pressure.

Boiling water canning: Process pints 15 minutes and quarts 20 minutes. For processing above 1,000 feet altitude, see page 11 for recommended time.

CHERRIES

Stem and wash cherries. Remove pits, if desired. If pitted, place cherries in an ascorbic acid solution (page 10) to prevent darkening of the stem end. Drain well. If canning whole cherries, prick each cherry with a clean needle to prevent splitting.

Hot Pack: Heat cherries in a large pot with ½ cup syrup (page 10), juice, or water per quart of cherries. Cover pot and bring to a boil. Pack hot cherries and cooking liquid in hot jars, leaving ½-inch headspace. Remove air bubbles. Clean jar rims. Position lids and secure with bands.

Pressure canning: Process at 6 pounds pressure, pints 8 minutes and quarts 10 minutes. For processing above 2,000 feet altitude, see page 11 for recommended pounds pressure.

Boiling water canning: Process pints 15 minutes and quarts 20 minutes. For processing above 1,000 feet altitude, see page 11 for recommended time.

NECTARINES AND PEACHES—YELLOW

Wash fully-ripened but not soft yellow nectarines or peaches. Do not process white flesh nectarines or peaches.

Skin can be left on nectarines. For peaches, loosen skin by dipping them 1 minute in boiling water, then in cold water. Peel. Cut fruit in halves and remove pits. Slice if desired. Place fruit in an ascorbic acid solution (page 10) to prevent darkening during preparation. Drain well.

Hot Pack: Add fruit and syrup (page 10), juice, or water to a large pot and bring to a boil. Pack hot fruit, cut side down, in hot jars, leaving ½-inch headspace. Cover with hot syrup, juice, or water, leaving ½-inch headspace. Remove air bubbles. Clean jar rims. Position lids and secure with bands.

Raw Pack: Pack raw fruit, cut side down, in hot jars, leaving ½-inch headspace. Cover with hot syrup, juice, or water, leaving ½-inch headspace. Remove air bubbles. Clean jar rims. Position lids and secure with bands.

Pressure canning (hot and raw pack): Process at 6 pounds pressure, pints and quarts 10 minutes. For processing above 2,000 feet altitude, see page 11 for recommended pounds pressure.

Boiling water canning:

Hot Pack: Process pints 20 minutes and quarts 25 minutes. For processing above 1,000 feet altitude, see page 11 for recommended time.

Raw Pack: Process pints 25 minutes and quarts 30 minutes. For processing above 1,000 feet altitude, see page 11 for recommended time.

PEARS

Wash pears. Peel, cut in halves lengthwise, and core. Place pears in an ascorbic acid solution (page 10) to prevent darkening during preparation. Drain well.

Hot Pack: Add pears and syrup (page 10), juice, or water to a large pot and bring to a boil. Boil 5 minutes. Pack hot pears in hot jars, leaving ½-inch headspace. Cover with hot syrup, juice, or water, leaving ½-inch headspace. Remove air bubbles. Clean jar rims. Position lids and secure with bands.

Pressure canning: Process at 6 pounds pressure, pints and quarts 10 minutes. For processing above 2,000 feet altitude, see page 11 for recommended pounds pressure.

Boiling water canning: Process pints 20 minutes and quarts 25 minutes. For processing above 1,000 feet altitude, see page 11 for recommended time.

PLUMS

Stem and wash firm, ripe plums. If plums are to be canned whole, prick each side with a fork. Freestone varieties may be cut in halves and pitted.

Hot Pack: Add plums and syrup (page 10), juice, or water to a large pot and bring to a boil. Boil 2 minutes. Cover pot and let stand 20 to 30 minutes. Pack hot plums in hot jars, leaving ½-inch headspace. Cover with hot syrup, juice, or water, leaving ½-inch headspace. Remove air bubbles. Clean jar rims. Position lids and secure with bands.

Raw Pack: Pack raw plums firmly in hot jars, leaving ½-inch headspace. Cover with hot syrup (page 10), juice, or water, leaving ½-inch headspace. Remove air bubbles. Clean jar rims. Position lids and secure with bands.

Pressure canning: Process at 6 pounds pressure, pints and quarts 10 minutes. For processing above 2,000 feet altitude, see page 11 for recommended pounds pressure.

Boiling water canning: Process pints 20 minutes and quarts 25 minutes. For processing above 1,000 feet altitude, see page 11 for recommended time.

RHUBARB

Trim off leaves. Wash stalks and cut into ½-inch to 1-inch pieces.

Hot Pack: Add rhubarb and ½ cup sugar per quart of rhubarb to a large pot. Let stand until juice appears. Heat rhubarb slowly to boiling. Pack hot rhubarb in hot jars, leaving ½-inch headspace. Remove air bubbles. Clean jar rims. Position lids and secure with bands.

Pressure canning: Process at 6 pounds pressure, pints and quarts 8 minutes. For processing above 2,000 feet altitude, see page 11 for recommended pounds pressure.

Boiling water canning: Process pints and quarts 15 minutes. For processing above 1,000 feet altitude, see page 11 for recommended time.

CANNING TOMATOES AND TOMATO PRODUCTS

Tomatoes and tomato products may be safely processed using the pressure canning method (pages 6 through 8) or the boiling water method (pages 22). For some tomato products, the pressure canning method may result in a more nutritious canned product.

Acidifying Tomatoes and Tomato Products

Tomatoes have a pH close to 4.6, which means it is necessary to take precautions to can them safely. First, carefully choose the tomatoes for canning. Use only tomatoes that are disease-free, preferably vine-ripened, and firm.

Second, an acid must be added to tomatoes whether they are processed using the boiling water method or pressure canning method. To ensure the safety of whole, crushed, or juiced tomatoes, add 1 tablespoon bottled lemon juice (not natural juice) or ¼ teaspoon citric acid per **pint** jar; for **quarts**, add 2 tablespoons bottled lemon juice or ½ teaspoon citric acid.

Salt

Tomatoes and tomato products may be canned with or without salt. Salt is used only for flavor, as it is not used in a large enough quantity to prevent spoilage. If salt is desired, use only canning or pickling salt. Table salt contains anti-caking agents that may cause cloudiness in the liquid inside the jars.

The recommended amount of salt is ½ teaspoon for each pint jar and 1 teaspoon for each quart jar.

Altitude Adjustments

When **pressure canning** at altitudes of 2,000 feet or below or **boiling water canning** at altitudes of 1,000 feet or below, process according to specific recipe. When canning at higher altitudes, process according to the following charts.

Altitude Chart for Pressure Canning Tomatoes

Altitude	Pounds Pressure
2,001–4,000 ft.	12 pounds
4,001–6,000 ft.	13 pounds
6,001–8,000 ft.	14 pounds

Altitude Chart for Boiling Water Canning Tomatoes

Altitude	Increase Processing Time
1,001–3,000 ft.	5 minutes
3,001–6,000 ft.	10 minutes
6,001–8,000 ft.	15 minutes

Processing time is the same at all altitudes.

CANNING RECIPES: TOMATOES

TOMATOES—WHOLE OR HALVED

(packed raw without added liquid)

Wash smooth, firm, ripe tomatoes. Loosen skins by dipping tomatoes 1 minute in boiling water, then in cold water. Peel and remove core. Leave whole or halve. Add bottled lemon juice or citric acid to hot jars (page 13). Add salt, if desired (page 13). Fill jars with raw tomatoes, pressing until spaces between them fill with juice. Leave ½-inch headspace. Remove air bubbles. Clean jar rims. Position lids and secure with bands.

Pressure canning: Process at 11 pounds pressure, pints and quarts 25 minutes. For processing above 2,000 feet altitude, see page 13 for recommended pounds pressure.

Boiling water canning: Process pints and quarts 85 minutes. For processing above 1,000 feet altitude, see page 13 for recommended time.

TOMATOES—WHOLE OR HALVED

(packed in water)

Wash smooth, firm, ripe tomatoes. Loosen skins by dipping tomatoes 1 minute in boiling water, then in cold water. Peel and remove core. Leave whole or halve, or if using large tomatoes, quarter.

Hot Pack: Place prepared tomatoes in a large pot and add just enough water to cover. Bring to a boil and boil gently for 5 minutes. Add bottled lemon juice or citric acid to hot jars (page 13). Add salt, if desired (page 13). Pack hot tomatoes in hot jars, leaving ½-inch headspace. Fill jars with hot cooking liquid, leaving ½-inch headspace. Remove air bubbles. Clean jar rims. Position lids and secure with bands.

Raw Pack: Add bottled lemon juice or citric acid to hot jars (page 13). Add salt, if desired (page 13). Pack prepared tomatoes in hot jars, leaving ½-inch headspace. Fill hot jars with boiling water, leaving ½-inch headspace. Remove air bubbles. Clean jar rims. Position lids and secure with bands.

Pressure canning: Process at 11 pounds pressure, pints and quarts 10 minutes. For processing above 2,000 feet altitude, see page 13 for recommended pounds pressure.

Boiling water canning: Process pints 40 minutes and quarts 45 minutes. For processing above 1,000 feet altitude, see page 13 for recommended time.

TOMATO JUICE

Wash ripe, juicy tomatoes. Remove stem ends. To prevent juice from separating, quickly cut about 1 pound of tomatoes into quarters and put directly into a large pot. Heat immediately to boiling while crushing. Continue to slowly add and crush freshly cut tomato quarters to the boiling mixture. Make sure the mixture boils constantly and vigorously while adding more tomatoes. Continue until the pot is three-quarters full. Simmer 5 minutes. If juice separation is not a concern, simply slice or quarter tomatoes into a large pot. Crush, heat, and simmer for 5 minutes before juicing.

Press heated juice through a sieve or food mill to remove skins and seeds. Heat juice again to boiling.

Add bottled lemon juice or citric acid to hot jars (page 13). Add salt, if desired (page 13). Fill hot jars with hot tomato juice, leaving ½-inch headspace. Remove air bubbles. Clean jar rims. Position lids and secure with bands.

Pressure canning: Process at 11 pounds pressure, pints and quarts 15 minutes. For processing above 2,000 feet altitude, see page 13 for recommended pounds pressure.

Boiling water canning: Process pints 35 minutes and quarts 40 minutes. For processing above 1,000 feet altitude, see page 13 for recommended time.

TOMATO SAUCE

Prepare and press as for making tomato juice (see recipe above). Heat in a large pot until sauce reaches desired consistency. Simmer until volume is reduced by about one-third for thin sauce or by one-half for thick sauce. Add bottled lemon juice or citric acid to hot jars (page 13). Add salt, if desired (page 13). Pour hot sauce into hot jars, leaving ½-inch headspace. Remove air bubbles. Clean jar rims. Position lids and secure with bands.

Pressure canning: Process at 11 pounds pressure, pints and quarts 15 minutes. For processing above 2,000 feet altitude, see page 13 for recommended pounds pressure.

Boiling water canning: Process pints 35 minutes and quarts 40 minutes. For processing above 1,000 feet altitude, see page 13 for recommended time.

SALSA

Process salsa using the boiling water method. Refer to pages 23 and 24 for tested canning recipe.

SPAGHETTI SAUCE WITHOUT MEAT

30 pounds tomatoes	¼ cup packed brown sugar
1 cup chopped onion	4 tablespoons dried parsley
1 cup chopped celery or green pepper	2 tablespoons dried oregano
1 pound fresh mushrooms, sliced (optional)	4½ teaspoons salt
5 cloves garlic, minced	2 teaspoons black pepper
¼ cup vegetable oil	

Note: Do not increase the proportion of onion, pepper, or mushrooms.

Wash tomatoes and dip in boiling water for 30 to 60 seconds or until skins split. Dip in cold water and slip off skins. Remove cores and quarter tomatoes. Boil 20 minutes, uncovered, in a large pot. Put through food mill or sieve. Sauté onion, celery or pepper, mushrooms (if desired), and garlic in vegetable oil until tender. Combine vegetables, tomatoes, sugar, parsley, oregano, salt, and pepper. Bring to a boil. Simmer, uncovered, stirring frequently until thick enough for serving. At this time the initial volume will have been reduced by nearly one-half. Fill hot jars with hot sauce, leaving 1-inch headspace. Remove air bubbles. Clean jar rims. Position lids and secure with bands.

Yield: About 9 pints

Pressure canning: Process at 11 pounds pressure, pints 20 minutes and quarts 25 minutes. For processing above 2,000 feet altitude, see page 13 for recommended pressure.

SPAGHETTI SAUCE WITH MEAT

30 pounds tomatoes	¼ cup packed brown sugar
2½ pounds ground beef or sausage	4 tablespoons dried parsley
1 cup chopped onion	2 tablespoons dried oregano
1 cup chopped celery or green pepper	4½ teaspoons salt
1 pound fresh mushrooms, sliced (optional)	2 teaspoons black pepper
5 cloves garlic, minced	

Note: Do not increase the proportion of onion, pepper, or mushrooms.

Wash tomatoes and dip in boiling water for 30 to 60 seconds or until skins split. Dip in cold water and slip off skins. Remove cores and quarter tomatoes. Boil 20 minutes, uncovered, in a large pot. Put through food mill or sieve. Brown beef or sausage. Add onion, celery or green pepper, mushrooms (if desired), and garlic. Cook until vegetables are tender. Combine with tomatoes in large pot. Add sugar, parsley, oregano, salt, and pepper. Bring to a boil. Simmer, uncovered, stirring frequently until thick enough for serving. At this time the initial volume will have been reduced by nearly one-half. Fill hot jars with hot sauce, leaving 1-inch headspace. Remove air bubbles. Clean jar rims. Position lids and secure with bands.

Yield: About 9 pints

Pressure canning: Process at 11 pounds pressure, pints 60 minutes and quarts 70 minutes. For processing above 2,000 feet altitude, see page 13 for recommended pressure.

PRESSURE CANNING VEGETABLES

Pressure canning is the only safe method for canning vegetables.

Young, tender, fresh, and slightly immature vegetables are better for canning than those which are overripe. As a rule, vegetables are best when canned immediately after picking, since flavor decreases upon standing and often unpleasant color changes take place. Avoid bruising vegetables because spoilage organisms grow more rapidly on bruised vegetables than on those that are unblemished.

Wash and prepare garden fresh vegetables as you would for cooking. When packing vegetables, always leave 1-inch headspace, or more if directed in recipe, in hot Mason jars.

To hot pack vegetables, precook in boiling water until heated through. Pack precooked vegetables into hot jars and cover with boiling water. Whenever possible, the precooking water should be used as liquid to cover the vegetables after packing into jars. However, there are a few vegetables, such as greens and asparagus, which make the cooking water bitter and undesirable to use.

To raw pack vegetables, simply place the prepared vegetables into hot jars and cover with boiling water.

Salt

Vegetables may be processed with or without salt. Salt is used only for flavor, as it is not used in a large enough quantity to prevent spoilage. If salt is desired, use only canning or pickling salt. Table salt contains anti-caking agents that may cause cloudiness in the liquid inside the jars.

The recommended amount of salt is ½ teaspoon for each pint jar and 1 teaspoon for each quart jar.

Altitude Adjustment

When pressure canning at altitudes of 2,000 feet or below, process according to specific recipe. When canning at higher altitudes, process according to the chart below.

Altitude Chart for Pressure Canning Vegetables

Altitude	Pounds Pressure
2,001–4,000 ft.	12 pounds
4,001–6,000 ft.	13 pounds
6,001–8,000 ft.	14 pounds

Processing time is the same at all altitudes.

CANNING RECIPES: VEGETABLES

ASPARAGUS

Wash and drain asparagus. Remove tough ends and scales. Rinse. Leave asparagus whole or cut into pieces.

Hot Pack: Cover asparagus with boiling water and boil 2 to 3 minutes. Pack hot asparagus loosely in hot jars, leaving 1-inch headspace.

Raw Pack: Pack raw asparagus tightly in hot jars, leaving 1-inch headspace.

Add salt, if desired (page 15). Cover with boiling water, leaving 1-inch headspace. Remove air bubbles. Clean jar rims. Position lids and secure with bands.

Process at 11 pounds pressure, pints 30 minutes and quarts 40 minutes. For processing above 2,000 feet altitude, see chart above for recommended pounds pressure.

BEANS OR PEAS—DRY

Sort out and discard any discolored beans. Rehydrate beans or peas using one of the following methods:

- ◆ Place dry beans or peas in a large pot and cover with water. Soak 12 to 18 hours in a cool place. Then drain.
- ◆ Cover beans with boiling water in a large pot. Boil 2 minutes, remove from heat, and soak 1 hour. Then drain.

Hot Pack: Cover beans soaked by either method with fresh water and boil 30 minutes. Add salt to hot jars, if desired (page 15). Fill jars with beans or peas and cooking water, leaving 1-inch headspace. Remove air bubbles. Clean jar rims. Position lids and secure with bands.

Process at 11 pounds pressure, pints 75 minutes and quarts 90 minutes. For processing above 2,000 feet altitude, see chart above for recommended pounds pressure.

BEANS—FRESH LIMA, BUTTER, PINTO, OR SOY

Shell and wash young, tender beans thoroughly.

Hot Pack: Cover beans with boiling water and bring to a boil. Boil 3 minutes. Pack hot beans loosely in hot jars, leaving 1-inch headspace.

Raw Pack: Pack raw beans loosely in hot jars, leaving 1-inch headspace in pint jars. For quarts, leave 1½-inch headspace if beans are small and 1¼-inch headspace if beans are large.

Add salt, if desired (page 15). Cover with boiling water, leaving 1-inch headspace. Remove air bubbles. Clean jar rims. Position lids and secure with bands.

Process at 11 pounds pressure, pints 40 minutes and quarts 50 minutes. For processing above 2,000 feet altitude, see chart above for recommended pounds pressure.

BEANS—GREEN, WAX, ITALIAN

Wash young, tender beans thoroughly. Remove stem and blossom ends or any strings. Leave whole or cut into 1-inch pieces.

Hot Pack: Cover beans with boiling water and boil 5 minutes. Pack hot beans loosely in hot jars, leaving 1-inch headspace.

Raw Pack: Pack raw beans tightly in hot jars, leaving 1-inch headspace.

Add salt, if desired (page 15). Cover with boiling water, leaving 1-inch headspace. Remove air bubbles. Clean jar rims. Position lids and secure with bands.

Process at 11 pounds pressure, pints 20 minutes and quarts 25 minutes. For processing above 2,000 feet altitude, see chart above for recommended pounds pressure.

BEETS

Trim tops of young, tender beets, leaving 1 to 2 inches of stem and root to reduce bleeding of color. Wash thoroughly.

Hot Pack: Cover beets with boiling water and boil 15 to 25 minutes or until skins slip off easily. Remove skins, stems, and roots. Small beets may be left whole. Cut medium or large beets into ½-inch cubes or slices; halve or quarter very large slices. Pack hot beets in hot jars, leaving 1-inch headspace.

Add salt, if desired (page 15). Cover with boiling water, leaving 1-inch headspace. Remove air bubbles. Clean jar rims. Position lids and secure with bands.

Process at 11 pounds pressure, pints 30 minutes and quarts 35 minutes. For processing above 2,000 feet altitude, see page 16 for recommended pounds pressure.

CARROTS

Wash thoroughly and scrape young, tender carrots. Carrots may be left whole, sliced, or diced.

Hot Pack: Cover carrots with boiling water, bring to a boil, and simmer 5 minutes. Pack hot carrots in hot jars, leaving 1-inch headspace.

Raw Pack: Pack raw carrots tightly in hot jars, leaving 1-inch headspace.

Add salt, if desired (page 15). Cover with boiling water, leaving 1-inch headspace. Remove air bubbles. Clean jar rims. Position lids and secure with bands.

Process at 11 pounds pressure, pints 25 minutes and quarts 30 minutes. For processing above 2,000 feet altitude, see page 16 for recommended pounds pressure.

CORN—WHOLE KERNEL

Husk and remove silk from young, tender, freshly picked corn; wash ears. Blanch 3 minutes in boiling water. Cut corn from cob at about three-fourths the depth of the kernel. Do not scrape cob.

Hot Pack: For each quart of corn, add 1 cup boiling water. Bring to a boil and simmer 5 minutes. Pack hot corn loosely in hot jars, leaving 1-inch headspace.

Raw Pack: Pack raw corn loosely in hot jars, leaving 1-inch headspace.

Add salt, if desired (page 15). Cover with boiling water, leaving 1-inch headspace. Remove air bubbles. Clean jar rims. Position lids and secure with bands.

Process at 11 pounds pressure, pints 55 minutes and quarts 85 minutes. For processing above 2,000 feet altitude, see page 16 for recommended pounds pressure.

GREENS

Sort young, tender, freshly picked greens; discard wilted or tough leaves, stems, and roots. Wash greens thoroughly.

Hot Pack: Blanch 1 pound of greens at a time, until well wilted (about 3 to 5 minutes). Pack hot greens loosely in hot jars, leaving 1-inch headspace.

Add salt, if desired (page 15). Cover with fresh boiling water, leaving 1-inch headspace. Remove air bubbles. Clean jar rims. Position lids and secure with bands.

Process at 11 pounds pressure, pints 70 minutes and quarts 90 minutes. For processing above 2,000 feet altitude, see page 16 for recommended pounds pressure.

MUSHROOMS

Trim stems and discolored parts of mushrooms. Soak mushrooms in cold water for 10 minutes to remove soil. Wash in clean water. Leave small mushrooms whole; cut larger ones in halves or quarters.

Hot Pack: Cover mushrooms with water and boil 5 minutes. Pack hot mushrooms in hot jars, leaving 1-inch headspace. For better color, add ¼ teaspoon of ascorbic acid per pint.

Add salt, if desired (page 15). Cover with boiling water, leaving 1-inch headspace. Remove air bubbles. Clean jar rims. Position lids and secure with bands.

Process at 11 pounds pressure, half-pints and pints 45 minutes. For processing above 2,000 feet altitude, see page 16 for recommended pounds pressure.

OKRA

Wash and trim young, tender okra pods. Remove stem, without cutting into pods if okra is to be canned whole. If desired, slice okra into 1-inch pieces.

Hot Pack: Cover okra with hot water and boil 2 minutes. Pack hot okra in hot jars, leaving 1-inch headspace.

Add salt, if desired (page 15). Cover with boiling water, leaving 1-inch headspace. Remove air bubbles. Clean jar rims. Position lids and secure with bands.

Process at 11 pounds pressure, pints 25 minutes and quarts 40 minutes. For processing above 2,000 feet altitude, see page 16 for recommended pounds pressure.

PEAS—GREEN

Wash and shell young, tender freshly picked green peas. Rinse.

Hot Pack: Cover peas with boiling water and bring to a boil. Boil 2 minutes. Pack hot peas loosely in hot jars, leaving 1-inch headspace. Do not shake or press down.

Raw Pack: Pack peas loosely in hot jars, leaving 1-inch headspace. Do not shake or press down.

Add salt, if desired (page 15). Cover with boiling water, leaving 1-inch headspace. Remove air bubbles. Clean jar rims. Position lids and secure with bands.

Process at 11 pounds pressure, pints and quarts 40 minutes. For processing above 2,000 feet altitude, see page 16 for recommended pounds pressure.

PEPPERS—HOT OR SWEET (including bell, chile, jalapeño, and pimiento)

Preparation of chile peppers: Cut two or four slits in each pepper and blister using one of the following methods:

- ◆ Oven or broiler method: Place chile peppers in a 400°F oven or broiler for 6 to 8 minutes until skins blister.
- ◆ Range-top method: Cover hot burner, either gas or electric, with heavy wire mesh. Place chiles on wire mesh for several minutes until skins blister.

Allow peppers to cool. Place in a pan and cover with a damp cloth. After several minutes, peel peppers. Remove stems and seeds.

Preparation of other peppers: Remove stems and seeds; blanch 3 minutes.

Hot Pack: Small peppers may be left whole. Large peppers may be quartered. Pack peppers loosely in hot jars, leaving 1-inch headspace.

Add salt, if desired (page 15). Cover with boiling water, leaving 1-inch headspace. Remove air bubbles. Clean jar rims. Position lids and secure with bands.

Process at 11 pounds pressure, pints 35 minutes. For processing above 2,000 feet altitude, see page 16 for recommended pounds pressure.

POTATOES—SWEET

Wash small to medium size sweet potatoes.

Hot Pack: Boil or steam sweet potatoes just until partially soft (15 to 20 minutes). Remove skins and cut into pieces of uniform size. **CAUTION!** Do not mash or puree potatoes as processing time may not be adequate for mashed or pureed product. Pack hot sweet potatoes in hot jars, leaving 1-inch headspace.

Add salt, if desired (page 15). Cover with boiling water, leaving 1-inch headspace. Remove air bubbles. Clean jar rims. Position lids and secure with bands.

Process at 11 pounds pressure, pints 65 minutes and quarts 90 minutes. For processing above 2,000 feet altitude, see page 16 for recommended pounds pressure.

POTATOES—WHITE

Wash, peel, and rinse new potatoes 1 to 2 inches in diameter. If desired, cut into ½-inch cubes. Place in ascorbic acid solution (1 teaspoon ascorbic acid to 1 gallon water) to prevent darkening. Drain.

Hot Pack: Cover potatoes with hot water and bring to a boil. Boil whole potatoes for 10 minutes, cubes for 2 minutes. Pack hot potatoes in hot jars, leaving 1-inch headspace.

Add salt, if desired (page 15). Cover with boiling water, leaving 1-inch headspace. Remove air bubbles. Clean jar rims. Position lids and secure with bands.

Process at 11 pounds pressure, pints 35 minutes and quarts 40 minutes. For processing above 2,000 feet altitude, see page 16 for recommended pounds pressure.

PUMPKIN AND WINTER SQUASH

Wash and remove seeds from small size pumpkins or squash. Cut into 1-inch slices and peel. Cut flesh into 1-inch cubes.

Hot Pack: Boil cubes in water for 2 minutes. **CAUTION!** Do not mash or puree as processing time may not be adequate for pureed product. Pack hot pumpkin or squash cubes loosely in hot jars, leaving 1-inch headspace.

Add salt, if desired (page 15). Cover with boiling water, leaving 1-inch headspace. Remove air bubbles. Clean jar rims. Position lids and secure with bands.

Process at 11 pounds pressure, pints 55 minutes and quarts 90 minutes. For processing above 2,000 feet altitude, see page 16 for recommended pounds pressure.

PRESSURE CANNING MEAT, GAME, AND POULTRY

Pressure canning is the only safe method for canning meat, game, and poultry.

Meat, game, and poultry should be handled carefully to avoid contamination. Keep it as cool as possible during preparation for canning, handle rapidly, and process as soon as it is packed.

Use good quality product that has been trimmed of gristle, fat, and bruised spots. The hot pack is recommended for the best liquid cover and quality during storage.

To make broth, place bony pieces in a large pot and cover with cold water. Simmer until meat is tender. Discard fat. Add boiling broth to hot jars packed with precooked meat or poultry.

Salt

Meat, game, and poultry may be canned with or without salt. Salt is used only for flavor, as it is not used in a large enough quantity to prevent spoilage. If salt is desired, use only canning or pickling salt. Table salt contains anti-caking agents that may cause cloudiness in the liquid inside the jars.

The recommended amount of salt is ½ teaspoon for each pint jar and 1 teaspoon for each quart jar.

Altitude Adjustment

When pressure canning at altitudes of 2,000 feet or below, process according to specific recipe. When canning at higher altitudes, process according to the chart below.

Altitude Chart for Pressure Canning Meat, Poultry, Fish, Seafood, and Soup

Altitude	Pounds Pressure
2,001–4,000 ft.	12 pounds
4,001–6,000 ft.	13 pounds
6,001–8,000 ft.	14 pounds

Processing time is the same at all altitudes.

CANNING RECIPES: MEAT

CUT-UP MEAT (strips, cubes, or chunks)

Bear, Beef, Pork, Lamb, Veal, and Venison

Remove excess fat. Soak strong-flavored wild meats for 1 hour in brine water containing 1 tablespoon of salt per quart of water. Rinse. Remove large bones and cut into desired pieces.

Hot Pack: Precook meat until rare by roasting, stewing, or browning in a small amount of oil. Do not use flour. Pack hot meat loosely in hot jars, leaving 1-inch headspace. Add salt, if desired (see above). Cover meat with boiling broth, water, or tomato juice (especially with wild game), leaving 1-inch headspace. Remove air bubbles. Clean jar rims. Position lids and secure with bands.

Raw Pack: Add salt, if desired (see above) to hot jars. Pack raw meat loosely in hot jars, leaving 1-inch headspace. **DO NOT ADD LIQUID.** Clean jar rims. Position lids and secure with bands.

Process at 11 pounds pressure, pints 75 minutes and quarts 90 minutes. For processing above 2,000 feet altitude, see chart above for recommended pounds pressure.

GROUND MEAT

Bear, Beef, Pork, Lamb, Veal, and Venison

Grind fresh meat in a food processor or meat grinder. For venison, add one part high quality pork fat to three or four parts venison before grinding. For sausage, use freshly made sausage seasoned with salt and cayenne pepper (do not use sage as it may cause a bitter flavor).

Hot Pack: Shape ground meat or sausage into patties or balls. Cook until lightly browned. Ground meat may also be cooked without shaping. Drain to remove excess fat. Pack hot meat loosely in hot jars, leaving 1-inch headspace. Add salt, if desired (see above). Cover meat with boiling water, broth, or tomato juice, leaving 1-inch headspace. Remove air bubbles. Clean jar rims. Position lids and secure with bands.

Process at 11 pounds pressure, pints 75 minutes and quarts 90 minutes. For processing above 2,000 feet altitude, see chart above for recommended pounds pressure.

CANNING RECIPES: POULTRY

CHICKEN, DUCK, GOOSE, TURKEY

Cut poultry into serving size pieces. If desired, remove bone.

Hot Pack: Precook poultry until two-thirds done by baking, boiling, or steaming. Pack hot poultry loosely in hot jars, leaving 1¼-inch headspace. Add salt, if desired (page 19). Cover poultry with hot broth, leaving 1¼-inch headspace. Remove air bubbles. Clean jar rims. Position lids and secure with bands.

Raw Pack: Add salt, if desired (page 19) to hot jars. Pack raw poultry loosely in hot jars, leaving 1¼-inch headspace. **DO NOT ADD LIQUID.** Clean jar rims. Position lids and secure with bands.

Process at 11 pounds pressure	<u>With Bone</u>	<u>Without Bone</u>
Pints	65 minutes	75 minutes
Quarts	75 minutes	90 minutes

For processing above 2,000 feet altitude, see page 19 for recommended pounds pressure.

RABBIT

Soak dressed rabbits 1 hour in water containing 1 tablespoon of salt per quart of water. Rinse. Use preparation procedures and processing times for poultry, omitting salt.

PRESSURE CANNING FISH AND SEAFOOD

Pressure canning is the only safe method for canning fish and seafood.

Only fresh fish should be canned and these should be bled and thoroughly cleaned of all viscera and membranes when caught, or as soon as possible. To prevent spoilage, keep fish and shellfish refrigerated or on ice to maintain a temperature of 40°F or below.

Altitude Adjustment

When pressure canning at altitudes of 2,000 feet or below, process according to specific recipe. When pressure canning above 2,000 feet, see page 19 for recommended pounds pressure.

CANNING RECIPES: FISH AND SEAFOOD

CLAMS—WHOLE OR MINCED

Keep clams on ice until ready to can. Scrub shells thoroughly and rinse.

Hot Pack: Steam 5 minutes and open. Remove clam meat. Collect and save clam juice. Wash clam meat in salted water using 1½ to 3 tablespoons of salt per gallon of water. Rinse. Cover clam meat with boiling water containing 2 tablespoons of lemon juice or ½ teaspoon of citric acid per gallon. Boil 2 minutes and drain. To make minced clams, grind clams with a meat grinder or food processor. Heat reserved clam juice to boiling. Pack clams loosely in hot jars, leaving 1-inch headspace. Add hot clam juice and, if needed, boiling water, leaving 1-inch headspace. Remove air bubbles. Clean jar rims. Position lids and secure with bands.

Process at 11 pounds pressure, half-pints 60 minutes and pints 70 minutes. For processing above 2,000 feet altitude, see page 19 for recommended pounds pressure.

FISH

Salmon, Trout, Steelhead, and other fish except Tuna

Remove head, tail, and fins. Wash fish in cold water.

Raw Pack: Split fish lengthwise and then cut into lengths that fit the jar size being used. Bones can be left in and skin left on, if desired. For halibut, remove the bones and skin. Pack fish tightly in hot jars, leaving 1-inch headspace. Add ½ teaspoon canning salt to each half-pint jar, 1 teaspoon to each pint jar, if desired. **DO NOT ADD LIQUID.** Clean jar rims. Position lids and secure with bands.

Process at 11 pounds pressure, half-pints and pints 100 minutes. For processing above 2,000 feet altitude, see page 19 for recommended pounds pressure.

TUNA

Remove viscera and clean fish thoroughly. Tuna may be canned either raw or precooked. Precooking removes most of the strong-flavored, natural oils.

Hot Pack: Place tuna belly-side down on a rack in the bottom of a large baking pan. Bake at 350°F for 1 hour. Refrigerate cooked fish overnight to firm the meat. Remove skin. Cut meat away from bones; cut out and discard bone, fin bases, and dark flesh. Quarter the pieces; cut quarters crosswise into lengths that fit the jar size being used. Add ½ teaspoon canning salt to each half-pint jar, 1 teaspoon to each pint jar, if desired. Pack fish into hot jars, pressing down gently to make a solid pack, leaving 1-inch headspace. Add water or oil to jars, leaving 1-inch headspace. Remove air bubbles. Clean jar rims. Position lids and secure with bands.

Raw Pack: Remove skin. Separate the meat into quarters by cutting the meat away from bones. Cut out and discard bone, fin bases, and dark flesh. Cut quarters crosswise into lengths that fit the jar size being used. Add ½ teaspoon canning salt to each half-pint jar, 1 teaspoon to each pint jar, if desired. Pack fish into hot jars, pressing down gently to make a solid pack, leaving 1-inch headspace. **DO NOT ADD LIQUID.** Clean jar rims. Position lids and secure with bands.

Process at 11 pounds pressure, half-pints and pints 100 minutes. For processing above 2,000 feet altitude, see page 19 for recommended pounds pressure.

PRESSURE CANNING STOCK AND SOUP

Pressure canning is the only safe method for canning stock and soup.

Stock and soup are quickly and easily canned. Generally, vegetable soup is more satisfactory if the stock and vegetables are canned separately and combined at the time of serving.

CANNING RECIPES: STOCK AND SOUP

BEEF STOCK

Saw or crack fresh trimmed beef bones to enhance extraction of flavor. Rinse bones.

Hot Pack: Place bones in a large pot and cover with water. Cover pot and simmer 3 to 4 hours. Remove bones. Cool broth; skim off and discard fat. Remove bits of meat from bones and add to broth, if desired. Reheat broth to boiling. Fill hot jars with hot broth, leaving 1-inch headspace. Remove air bubbles. Clean jar rims. Position lids and secure with bands.

Process at 11 pounds pressure, pints 20 minutes and quarts 25 minutes. For processing above 2,000 feet altitude, see page 19 for recommended pounds pressure.

CHICKEN STOCK

Hot Pack: Place large carcass bones in a large pot; add enough water to cover bones. Cover pot and simmer 30 to 45 minutes or until meat can be easily removed from bones. Remove bones. Cool broth; skim off and discard fat. Remove bits of meat from bones and add to broth, if desired. Reheat broth to boiling. Fill hot jars with hot broth, leaving 1-inch headspace. Remove air bubbles. Clean jar rims. Position lids and secure with bands.

Process at 11 pounds pressure, pints 20 minutes and quarts 25 minutes. For processing above 2,000 feet altitude, see page 19 for recommended pounds pressure.

SOUP

Vegetable, Dried Bean or Pea, Meat, Poultry, or Seafood

Choose your favorite vegetables, dried beans or peas, meat, poultry, or seafood ingredients for soup as long as those ingredients have their own individual canning recommendations. Do not use ingredients for which there are no canning recommendations.

CAUTION! In accordance with USDA guidelines, do not add noodles or other pasta, rice, cured or brined meat, flour, cream, milk, or other thickening agents to home canned soup as processing time may not be adequate.

Hot Pack: Prepare vegetables, meat, poultry, and seafood as described in the hot pack directions for the individual ingredients. **If dried beans or peas are used, they must be fully rehydrated before adding to other ingredients** (see page 16) Combine solid ingredients with meat broth, tomatoes, or water to cover. Boil 5 minutes. Salt to taste, if desired. Fill jars halfway with solid ingredients and then add soup liquid, leaving 1-inch headspace. Remove air bubbles. Clean jar rims. Position lids and secure with bands.

Process at 11 pounds pressure, pints 60 minutes and quarts 75 minutes. If soup contains seafood, process pints and quarts 100 minutes. For processing above 2,000 feet altitude, see page 19 for recommended pounds pressure.

HOW TO CAN FOODS USING BOILING WATER METHOD

If using your canner on an induction or smooth-top range and using the boiling water method of canning for quart jars, consult with the range/cooktop manufacturer for any weight restrictions. The filled canner weight is over 50 pounds.

1. Place cooking/canning rack on bottom of canner. Fill canner halfway with water.
2. Remove overpressure plug and pressure regulator from canner cover and set aside.
3. Preheat water to 140°F for raw-packed foods and to 180°F for hot-packed foods.
4. Use jar lifter to place filled jars, with lids and bands fastened according to manufacturer's directions, on cooking/canning rack in canner.
5. Check water level. Add more boiling water, if needed, so the water level is at least 1 inch above jar tops.
6. Look through the vent pipe on the canner cover to be certain it is clear before placing cover on canner. To clean the vent pipe, draw a pipe cleaner or small brush through the opening; see page 7.
7. Place cover on canner, aligning the **V** mark on the cover with the inverted **V** mark on the body handle (Fig. G, page 7). Lock securely by turning in the direction indicated to close the cover (clockwise). **Cover handles must be above body handles. Do not force beyond this position.**
8. Turn heat on stove to its highest setting until water boils vigorously.
9. Set a timer for the minutes required for processing the food based on tested canning recipe.
10. Lower the heat setting to maintain a gentle boil throughout processing.
11. Add more boiling water, if needed, to keep the water level above the jars.
12. When jars have been processed for the recommended time, turn off the heat and remove the canner cover. Let canner cool for 5 minutes.
13. Using a jar lifter, remove jars by lifting them straight up. Be careful not to tilt them, which causes liquid to siphon from jars. Place jars upright on a board or dry towel, away from drafts. Do not retighten bands. Allow jars to cool naturally. Check seals no earlier than 12 hours, but no later than 24 hours. See pages 5 for "After Processing" information.
14. When canning is complete, allow canner to cool completely before cleaning.

CANNING RECIPES: BOILING WATER METHOD

The recipes below and on pages 23 and 24 are safely canned by the boiling water method. Do not pressure can these recipes because the food quality would be unacceptable.

IMPORTANT: Jars used for the three preserve recipes (marked with a ♦) will need to be sterilized because the processing time is less than 10 minutes. To sterilize the jars, boil them for 10 minutes. If you live at an altitude of 1,000 feet or more, boil an additional minute for each 1,000-foot increase in altitude. If preferred, instead of sterilizing the jars, you can increase the processing time to 10 minutes. The additional processing time is not harmful to most gels.

Reminder: If your altitude is above 1,000 feet, the processing time needs adjustment. See pages 11 and 13.

For boiling water method processing procedures for fruits and tomatoes, refer to pages 10 through 15.

QUICK FRESH-PACK DILL PICKLES

8 pounds 3- to 5-inch pickling cucumbers	2 tablespoons whole mixed pickling spice
2 gallons water	3 tablespoons whole mustard seed (1 teaspoon per pint jar)
1¼ cups canning or pickling salt (divided)	14 heads of fresh dill (1½ heads per pint jar)
1½ quarts vinegar (5% acidity)	OR 4½ tablespoons dill seed (1½ teaspoons per pint jar)
¼ cup sugar	
2 quarts water	

Wash cucumbers. Cut ¼-inch slice off blossom end and discard, but leave ¼-inch of stem attached. Dissolve ¾ cup salt in 2 gallons water. Pour over cucumbers and let stand 12 hours. Drain. In a large pot combine vinegar, ½ cup salt, sugar, and 2 quarts water. Add mixed pickling spices tied in a clean, white cloth. Heat to boiling. Fill hot jars with cucumbers. Add 1 teaspoon mustard seed and 1½ heads fresh dill per pint. Cover with boiling pickling liquid, leaving ½-inch headspace. Remove air bubbles. Clean jar rims. Position lids and secure with bands. Process pints 10 minutes and quarts 15 minutes.

Yield: About 7 to 9 pints

APPLE BUTTER❖

Recommended apples include Jonathan, Winesap, Stayman, Golden Delicious, and McIntosh.

8 pounds apples
2 cups apple cider
2 cups vinegar
2¼ cups sugar

2½ cups packed brown sugar
2 tablespoons ground cinnamon
1 tablespoon ground cloves

Wash apples. Remove stems, quarter, and core fruit. Cook apples slowly in apple cider and vinegar until soft. Press fruit through a colander, food mill, or strainer. Cook fruit pulp with sugar and spices, stirring frequently. To test for doneness, remove a spoonful and hold it away from steam for 2 minutes. It is done if the butter remains mounded on the spoon. Another way to determine when the butter is cooked adequately is to spoon a small quantity onto a plate. When a rim of liquid does not separate around the edge of the butter, it is ready for canning. Ladle hot butter into hot jars, leaving ¼-inch headspace. Remove air bubbles. Clean jar rims. Position lids and secure with bands. Process half-pints and pints 5 minutes.

Yield: 8 to 9 pints

Apple Butter recipe adapted from the "Complete Guide to Home Canning," Agriculture Information Bulletin No. 539, USDA, revised 2009. National Center for Home Food Preservation.

RHUBARB STRAWBERRY JAM❖

1 cup cooked red-stalked rhubarb
(about 1 pound rhubarb and ¼ cup water)
2½ cups crushed strawberries (about 1½ quarts)

6½ cups sugar
1 pouch liquid pectin

To prepare fruit: Wash rhubarb and slice thin or chop; do not peel. Add water, cover, and simmer until rhubarb is tender, about 1 minute. Sort and wash fully ripe strawberries; remove stems and caps. Crush berries.

To make jam: Measure prepared rhubarb and strawberries into a large pot. Add sugar and stir well. Place on high heat and, stirring constantly, bring quickly to a full rolling boil that cannot be stirred down. Boil hard for 1 minute, stirring constantly. Remove from heat and stir in pectin. Skim foam, if necessary. Immediately ladle hot jam into hot jars, leaving ¼-inch headspace. Remove air bubbles. Clean jar rims. Position lids and secure with bands. Process half-pints and pints 5 minutes.

Yield: About 7 or 8 half-pints

GRAPE JELLY❖

5 cups grape juice (about 3½ pounds grapes
and about 1 cup water)

1 package powdered pectin
7 cups sugar

To prepare juice: Sort, wash, and remove stems from fully ripe grapes. In a large pot, crush about 3½ pounds of grapes and add just enough water to cover grapes, about 1 cup. Cover and bring to boil on high heat. Reduce heat and simmer for 10 minutes. Pour contents of pot into a damp jelly bag and suspend the bag to drain the juice into a large bowl. Allow juice to drain undisturbed overnight in a cool place. Strain through two thicknesses of damp cheesecloth to remove any crystals that have formed.

To make jelly: In a large pot combine juice and pectin; stir well. Place on high heat and, stirring constantly, bring quickly to a full rolling boil that cannot be stirred down. Add sugar, continue stirring, and heat again to a full rolling boil. Boil hard for 1 minute. Remove from heat; skim off foam quickly. Immediately ladle hot jelly into hot jars, leaving ¼-inch headspace. Remove air bubbles. Clean jar rims. Position lids and secure with bands. Process half-pints and pints 5 minutes.

Yield: About 8 half-pints

Rhubarb Strawberry Jam and Grape Jelly adapted from "How to Make Jellies, Jams, and Preserves at Home," Home and Garden Bulletin No. 56. Extension Service, United States Department of Agriculture. National Center for Home Food Preservation, June 2005.

TOMATO SALSA

**This recipe works best with paste tomatoes, such as Roma. Slicing tomatoes, such as Plum or Beefsteak, require a much longer initial cooking time to achieve a desirable consistency.*

7 quarts peeled, cored, chopped paste or
plum tomatoes*
5 cups chopped onion
4 cups seeded, chopped long green chiles
½ cup seeded, finely chopped jalapeño peppers
6 cloves garlic, finely chopped
2 cups bottled lemon or lime juice

2 tablespoons salt
1 tablespoon black pepper
Optional ingredients:
3 tablespoons dried oregano
2 tablespoons ground cumin
2 tablespoons fresh cilantro

CAUTION! Wear plastic or rubber gloves and do not touch your face while handling or cutting hot peppers. If you do not wear gloves, wash hands thoroughly with soap and water before touching your face or eyes.

The jalapeño peppers do not need to be peeled. The skin of the long green chiles may be tough. If you choose to peel chiles, wash and dry them and then slit each pepper along the side to allow steam to escape. Blister skins by placing peppers in a hot oven (400°F) or under a broiler for 6 to 8 minutes until skins blister. After blistering skins, place peppers in a pan and cover with a damp cloth. Cool several minutes; peel off skins. Discard seeds and chop.

Wash tomatoes and dip in boiling water for 30 to 60 seconds or until skins split. Dip in cold water, slip off skins, and remove cores. Combine all ingredients except oregano, cumin, and cilantro in a large pot and bring to a boil, stirring frequently, then reduce heat and simmer 10 minutes. Add oregano, cumin, and cilantro, if desired, and simmer for another 20 minutes, stirring occasionally.

Ladle hot salsa into hot jars, leaving ½-inch headspace. Remove air bubbles. Clean jar rims. Position lids and secure with bands. Process pints 15 minutes.

Yield: About 16 to 18 pints

This completes the canning information. For additional information, visit www.GoPresto.com/content/canning.

The information below and on pages 25 through 35 is for pressure cooking foods in your pressure canner.

HOW TO PRESSURE COOK FOODS IN YOUR PRESSURE CANNER

To assure the very best results every time, carefully follow these step-by-step instructions for pressure cooking. You may find it helpful to refer back to the parts diagrams on pages 2 and 3.

1. Prepare ingredients according to the directions in the selected pressure cooking recipe. Pour liquid into the canner body, as specified in the recipe or timetable. This liquid is usually water. However, some recipes will call for other liquids, such as broth, juice, or wine.
2. Place the cooking rack in the canner, if called for in the recipe (see helpful hints on page 26 for guidance on when to use).
3. **IMPORTANT:** Look through the vent pipe to make certain that it is clear (Fig. D, page 7). Refer to the safety information on page 25. Also check that the overpressure plug is seated properly in the cover (Fig. K, page 9). Make sure the two metal parts of the air vent/cover lock are securely fastened (Fig. L, page 10).
4. Place the cover on the canner, aligning the **V** mark on the cover with the inverted **V** mark on the body handle (Fig. H, page 7). Press down on the cover handles to compress the sealing ring and turn the cover in the direction indicated to close (clockwise) until the cover handles are above the body handles. Do not rotate the cover beyond this point.
5. Position the canner on a level burner and range only. Use on a tilted burner or range may interfere with the operation of the pressure regulator. For electric coil, smooth-top, and induction ranges, use the element that most closely matches the 9-inch diameter of the canner bottom. This is the portion of the canner bottom which comes in contact with the element. Do not use on any outdoor LP gas burner or a gas range over 12,000 BTU's.

CAUTION! Do not overheat or run the canner dry, use on too large of an element, or use a burner over 12,000 BTU's. Doing so may soften the canner and cause the bottom to warp which may result in the stainless steel clad base separating from the canner. It may also result in property damage and/or personal injury.

6. Place the pressure regulator on the vent pipe. Using a high setting, heat the canner until the pressure regulator begins to rock.
7. Cooking time begins when the pressure gauge registers 15 pounds pressure. Adjust heat to maintain 15 pounds pressure on the pressure dial gauge to prevent excess steam from escaping. (If the pressure regulator begins to rock before 15 pounds pressure is reached on the pressure dial gauge, lower the heat to maintain a slow, steady rocking motion of the pressure regulator and cook at this pressure.) To watch a video of the regulator rocking motion, visit www.GoPresto.com/ppc/rocking.
8. Cook for the length of time specified in the recipe or cooking chart. When the cooking time is complete, turn off the burner and remove the canner from the heat source. **NOTICE:** Lift the pressure canner to remove it from the burner. Sliding any cookware can leave scratches on stovetops.
9. Reduce pressure according to recipe. If the recipe states "let pressure drop of its own accord," set the canner aside to cool until pressure is completely reduced.

If the recipe states "cool canner at once," cool the pressure canner under a running water faucet or pour cold water over it.

NOTICE: Do not set a hot canner directly on the bottom of a molded sink as it could damage the sink. Instead, place the canner on a cooling rack in the sink.

Pressure is completely reduced when the air vent/cover lock has dropped. Do not use the pressure dial gauge as an indicator of when pressure is completely reduced.

If the air vent/cover lock remains in its raised position, there is still pressure inside the pressure canner. Continue to cool until the air vent/cover lock drops.

10. After pressure has been completely reduced, remove the pressure regulator. **Always remove the pressure regulator before opening the cover.**
11. To open the cover, turn it counterclockwise until the inverted **V** mark on the body handle aligns with the **V** mark on the cover. Then, lift the cover toward you to keep any steam away from you.
CAUTION! If the cover seems to stick or is hard to turn, there may still be some pressure in the canner. **Do not force the cover off.** Continue cooling the canner until the air vent/cover lock has dropped and the cover turns easily.
12. Remove food and serve. Let canner cool completely before cleaning.

IMPORTANT SAFETY INFORMATION

Cooking under pressure enables you to prepare food both quickly and deliciously. If used properly, your pressure canner is one of the safest appliances in your kitchen.

WARNING! To ensure safe operation, make sure you always observe the following simple rules whenever you use the pressure canner. Failure to do so could result in bodily injury or property damage.

1. **Never overfill the pressure canner.** The pressure regulator is designed to maintain cooking pressure at a safe level. It relieves excess pressure through the vent pipe as it gently rocks back and forth. Many foods tend to expand when cooked. If the canner is overfilled, expansion of food may cause the vent pipe to become blocked. If the vent pipe becomes blocked, it cannot relieve excess pressure.

There are a few foods such as rice, grains, dry beans and peas, and soup which expand so much or foam and froth while cooking that the canner should never be filled above the $\frac{1}{2}$ fill line. For other foods, never fill the canner above the $\frac{2}{3}$ fill line.

For your convenience, both the $\frac{2}{3}$ and $\frac{1}{2}$ full levels are marked by indentations on the side of the pressure canner body (Fig. M). The top marking indicates the $\frac{2}{3}$ full level and the middle marking the $\frac{1}{2}$ full level. (The lowest marking is the 3-quart water level marking used for pressure canning.) In addition, in each section of the recipes you will find instructions on the maximum fill level for each type of food.

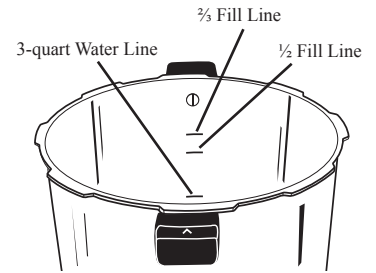

Fig. M

2. **Always add cooking liquid.** If an empty pressure canner is left on a hot burner or if a canner boils dry and is left on a heated burner, the canner will overheat excessively causing possible discoloration and/or warping of the canner. It may also result in property damage and/or personal injury. If the canner warps, this may cause the stainless steel clad base to separate from the canner.
3. **Always look through the vent pipe before using the canner to make sure it is clear.** If the vent pipe is blocked, it cannot function as it should and thus cannot relieve excess pressure. Pressure may then build to unsafe levels. To clean the vent pipe, draw a pipe cleaner or small brush through the opening. Also clean the vent pipe nut as shown (Fig. E and Fig. F page 7).
4. **Always fully close the pressure canner.** The canner is fully closed when the cover handles are above the body handles. Your pressure canner has specially designed lugs on the cover and body which lock the cover in place when the canner is fully closed. However, if the canner is not fully closed, the lugs cannot lock the cover onto the body. Therefore, it is possible that pressure could build inside the canner and cause the cover to come off and result in bodily injury or property damage. Always be sure the cover handles are above the body handles. Do not turn past handle alignment.
5. **Never open the canner when it contains pressure.** The air vent/cover lock provides a visual indication of pressure inside the canner. When it is up, there is pressure. When it is down, there is no pressure in the canner and the canner can be opened. If the canner is opened before all of the pressure is released, the contents will erupt and could cause bodily injury or property damage.
6. **Replace the sealing ring and overpressure plug if they become hard, deformed, cracked, worn, pitted, or soft and sticky. Always replace the overpressure plug when replacing the sealing ring.** Both the sealing ring and overpressure plug are made of rubber, and when new, are soft and pliable. Over time, depending on the frequency and type of use, rubber becomes hard and inflexible. Replace the sealing ring and overpressure plug at least every 3 years.

The overpressure plug is a secondary pressure relief valve designed to relieve excess pressure by releasing from the canner cover in the event that the vent pipe becomes blocked. When hard and inflexible, the overpressure plug loses its ability to act as a secondary pressure relief valve. It should be replaced immediately.

Should the overpressure plug ever be forced out of the cover due to excess pressure while cooking, call the Presto Consumer Service Department at 1-800-877-0441 for assistance in determining why this happened. **Do not attempt to use the released overpressure plug.**

7. **Always follow the special procedures found in the instruction book when pressure cooking dry beans and peas.** During cooking, dry beans and peas tend to froth and foam which could cause the vent pipe to become blocked. Therefore, they need to be soaked and cooked according to the instructions on page 31 to minimize frothing and foaming during cooking.
8. **Never pressure cook applesauce, cranberries, rhubarb, cereals, pasta, split peas, dried soup mixes, or dry beans and peas which are not listed in the chart on page 32.** These foods expand so much as a result of foaming and frothing that they should never be cooked under pressure.

HELPFUL HINTS FOR PRESSURE COOKING

- ◆ Your favorite recipes may be adjusted for cooking in the canner by following the general directions in this book for the particular type of food being cooked. Decrease the length of cooking time by two-thirds, since pressure cooking is much faster than ordinary cooking methods. Recipes are cooked at 15 pounds pressure.

Because there is little evaporation from the canner, the amount of liquid should be decreased. Add about 2 cups more liquid than desired in the finished product. There must always be water or some other liquid in the bottom of the canner to form the necessary steam.

- ◆ Use the cooking rack when it is desirable to cook foods out of the cooking liquid. When foods are pressure cooked out of the liquid, flavors will not intermingle. Therefore, it is possible to cook several foods at once, as long as they have similar cooking times. If it is desirable to blend flavors, do not use the cooking rack.
- ◆ When the body of your canner is heated, the metal expands. Therefore, it may be difficult to close the cover on a heated body. When this happens, allow the canner to cool slightly and then place the cover on the body.
- ◆ Foods are quickly cooked in the canner. Therefore, to prevent overcooking it is important to accurately time the cooking period.
- ◆ If your cooked food has more liquid than you desire, simmer to evaporate excess liquid.
- ◆ When pressure cooking at high altitudes, the cooking time needs to be increased 5% for every 1,000 feet above the first 2,000 feet. Following this rule, the time would be increased as follows:

3,000 ft. ...	5%	5,000 ft. ...	15%	7,000 ft. ...	25%
4,000 ft. ...	10%	6,000 ft. ...	20%	8,000 ft. ...	30%

- ◆ If you have questions on recipes or timetables, contact the Test Kitchen by calling 1-800-368-2194 or email us through our website at www.GoPresto.com.

PRESSURE COOKING MEAT

Savory, tender meat is easily prepared in the canner. An important step is to sear meat to a crispy brown on all sides to seal in natural juices.

Meat recipes are cooked at 15 pounds pressure.

Cooking time depends on the amount and distribution of fat and bone, toughness, size and thickness of cut, grade and cut of meat, and the manner in which the meat fits into the canner. Rolled roasts require a longer cooking time per pound than roasts with bone. Short, chunky roasts take longer to cook than long, flat roasts. Because of the difference in thickness, a small, thick roast requires a longer cooking time per pound than a heavier, flat roast.

After pressure cooking time is completed, serving size pieces of meat may be quick cooled. However, when cooking a roast cut of meat, pressure must drop of its own accord to be sure that pressure is reduced both within the roast and the canner.

DO NOT FILL CANNER OVER $\frac{2}{3}$ FULL!

The following recipes are intended for pressure cooking and should not be canned.

COOKING RECIPES: MEAT

BEEF STEW

4 pounds beef, cut into 1-inch cubes
3 tablespoons vegetable oil
12 potatoes, halved
4 onions, sliced
12 carrots, halved
3 cups green beans

3 cups tomatoes
Salt and pepper
2 cups water
*** * * * ***
3 tablespoons flour
 $\frac{3}{4}$ cup water

Heat oil in canner over medium heat and brown meat. Add potatoes, onions, carrots, green beans, and tomatoes. Season with salt and pepper, as desired. Add water. Close cover securely. Place pressure regulator on vent pipe and COOK 8 MINUTES at 15 pounds pressure. Let pressure drop of its own accord. Make a paste of flour and $\frac{3}{4}$ cup water and stir into stew to thicken.

15-18 servings.

BEEF POT ROAST

9 pounds beef shoulder or rump roast
3 tablespoons vegetable oil
4 cups water

Salt and pepper
2 onions, sliced
2 bay leaves

Heat oil in canner over medium heat. Brown roast well on all sides; remove roast. Pour water into canner. Place cooking rack and roast in canner. Season roast with salt and pepper. Add onions and bay leaves. Close cover securely. Place pressure regulator on vent pipe and COOK 45 MINUTES at 15 pounds pressure. Let pressure drop of its own accord.

15-18 servings.

BRAISED BEEF

9 pounds boneless beef, round or rump roast
3 tablespoons vegetable oil
Salt and pepper
4 cups water

1 cup diced turnips
1 cup diced carrots
3 onions, chopped
1 cup chopped celery

Heat oil in canner over medium heat. Brown roast well on all sides. Season roast with salt and pepper. Add water, turnips, carrots, onions, and celery. Close cover securely. Place pressure regulator on vent pipe and COOK 40 MINUTES at 15 pounds pressure. Let pressure drop of its own accord.

15-18 servings.

ITALIAN BEEF

9 pounds rump or chuck roast
3 tablespoons vegetable oil
3 onions, chopped
2 cups diced celery
3 carrots, chopped
2 cups sliced mushrooms

3 bay leaves
1 tablespoon salt, or as desired
3 (6-ounce) cans tomato paste
2½ cups beef broth
1½ cups red wine

Heat oil in canner over medium heat. Brown roast well on all sides. Add onions, celery, carrots, mushrooms, bay leaves, and salt. Blend tomato paste with broth and wine. Pour over meat. Close cover securely. Place pressure regulator on vent pipe and COOK 35 MINUTES at 15 pounds pressure. Let pressure drop of its own accord. Thicken gravy, if desired.

15-18 servings.

PORK CHOPS WITH VEGETABLES

15 pork chops, ¾ inch thick
3 tablespoons vegetable oil
Salt and pepper

15 potatoes
15 carrots
4 cups water

Heat oil in canner over medium heat. Brown pork chops on both sides. Season with salt and pepper. Add potatoes, carrots, and water. Close cover securely. Place pressure regulator on vent pipe and COOK 10–12 MINUTES at 15 pounds pressure. Let pressure drop of its own accord.

15 servings.

SHORT RIBS OF BEEF

10 pounds beef short ribs, cut into serving pieces
3 tablespoons vegetable oil
3 onions, chopped
1 cup chopped celery

1 green pepper, chopped
2 cups tomatoes
1 tablespoon salt, or as desired
1 teaspoon black pepper
4 cups water

Heat oil in canner over medium heat. Brown ribs on all sides. Add onions, celery, green pepper, tomatoes, salt, pepper, and water. Close cover securely. Place pressure regulator on vent pipe and COOK 40 MINUTES at 15 pounds pressure. Let pressure drop of its own accord.

18-20 servings.

SWISS STEAK

**12 pounds round steak, 1 inch thick,
cut into serving pieces**
3 tablespoons vegetable oil
Salt and pepper

2 onions, chopped
1 green pepper, chopped
4 cups tomato juice

Heat oil in canner over medium heat. Brown meat on both sides. Add salt, pepper, onions, green pepper, and tomato juice. Close cover securely. Place pressure regulator on vent pipe and COOK 15 MINUTES at 15 pounds pressure. Let pressure drop of its own accord.

24 servings.

PORK ROAST

6 pounds pork roast
2 tablespoons vegetable oil
Salt and pepper

2 onions, sliced
4 cups water

Heat oil in canner over medium heat. Brown roast well on all sides. Season with salt, pepper, and sliced onion; add water. Close cover securely. Place pressure regulator on vent pipe and COOK 60 MINUTES at 15 pounds pressure. Let pressure drop of its own accord.

12-15 servings.

SPARERIBS AND SAUERKRAUT

6 pounds spareribs, cut into serving pieces
3 tablespoons vegetable oil
Salt and pepper

3 quarts sauerkraut
3 tablespoons packed brown sugar
4 cups water

Heat oil in canner over medium heat. Brown ribs on both sides. Season with salt and pepper. Place sauerkraut over ribs and sprinkle with brown sugar. Add water. Close cover securely. Place pressure regulator on vent pipe and COOK 15 MINUTES at 15 pounds pressure. Let pressure drop of its own accord.

12 servings.

SPARERIBS WITH BARBECUE SAUCE

10 pounds spareribs, cut into serving pieces
Salt and pepper
Paprika
3 tablespoons vegetable oil
4 onions, sliced
2 cups ketchup

1 cup vinegar
2 tablespoons Worcestershire sauce
1 teaspoon chili powder
1 teaspoon celery seed
1 cup water

Season spareribs with salt, pepper, and paprika. Heat oil in canner over medium heat. Brown ribs on all sides. Add onion. Combine ketchup, vinegar, Worcestershire sauce, chili powder, celery seed, and water; pour over meat in canner. Close cover securely. Place pressure regulator on vent pipe and COOK 15 MINUTES at 15 pounds pressure. Let pressure drop of its own accord.

12-15 servings.

SPAGHETTI MEAT SAUCE

6 pounds ground beef
4 onions, chopped
2 cups chopped celery
2 green peppers, diced
4 cloves garlic, minced
1 tablespoon salt, or as desired

3 quarts tomato juice
3 (12-ounce) cans tomato paste
¼ cup sugar
2 tablespoons dried oregano
½ teaspoon cayenne pepper

Heat canner and brown beef. Add onions, celery, green peppers, garlic, salt, tomato juice, tomato paste, sugar, oregano, and cayenne pepper. Close cover securely. Place pressure regulator on vent pipe and COOK 10 MINUTES at 15 pounds pressure. Let pressure drop of its own accord. Serve sauce over spaghetti and sprinkle with Parmesan cheese.

20-24 servings.

CHILI CON CARNE

6 pounds ground beef
4 onions, chopped
2 green peppers, chopped
2 cloves garlic, minced
3 (14- to 15-ounce) cans tomatoes
1 (14- to 15-ounce) can tomato sauce
2 tablespoons chili powder

1 tablespoon salt, or as desired
½ teaspoon cayenne pepper
2 cups water
* * * * *
3 (14- to 15- ounce) cans kidney beans,
drained and rinsed

Heat canner and brown beef. Add onions, green pepper, and garlic and brown lightly. Add tomatoes, tomato sauce, chili powder, salt, cayenne pepper, and water. Close cover securely. Place pressure regulator on vent pipe and COOK 15 MINUTES at 15 pounds pressure. Let pressure drop of its own accord. Stir in kidney beans and heat through.

18-20 servings.

NEW ENGLAND BOILED DINNER

4 pounds ham shank
4 cups water
* * * * *
12 potatoes, halved

12 onions, halved
12 carrots, halved
1 cabbage, cut in wedges
½ teaspoon black pepper

Place ham and water in canner. Close cover securely. Place pressure regulator on vent pipe and COOK 20 MINUTES at 15 pounds pressure. Let pressure drop of its own accord. Add potatoes, onions, carrots, cabbage, and pepper. Close cover securely. Place pressure regulator on vent pipe and COOK 8 MINUTES at 15 pounds pressure. Let pressure drop of its own accord.

12 servings.

MEAT CABBAGE ROLLS

2 large heads cabbage
Hot water
3 pounds ground beef
1 tablespoon salt, or as desired
¾ teaspoon black pepper

3 cups cooked rice
3 cups milk
⅓ cup packed brown sugar
4 cups water

Dip cabbage leaves in hot water. Dry leaves on towel. Combine meat, salt, pepper, cooked rice, and milk. Place a tablespoon of meat mixture onto each leaf; roll leaf around meat and fasten with toothpick. Place cooking rack and cabbage rolls in canner. Sprinkle with brown sugar and add water. Close cover securely. Place pressure regulator on vent pipe and COOK 10 MINUTES at 15 pounds pressure. Let pressure drop of its own accord.

12-15 servings.

PORK HOCKS WITH SAUERKRAUT AND POTATOES

9 pounds pork hocks
4 cups water
½ teaspoon black pepper
* * * * *

2 quarts sauerkraut
12 potatoes, halved
2 onions, chopped

Place hocks, water, and pepper in canner. Close cover securely. Place pressure regulator on vent pipe and COOK 45 MINUTES at 15 pounds pressure. Let pressure drop of its own accord. Add sauerkraut, potatoes, and onions. Close cover securely. Place pressure regulator on vent pipe and COOK 10 MINUTES at 15 pounds pressure. Let pressure drop of its own accord.

12-15 servings.

CORNEB BEEF

12 pounds corneb beef
4 cups water

3 cloves garlic
3 bay leaves

Cut garlic cloves in small pieces and insert in beef with a sharp knife. Place meat and water in canner. Add bay leaves. Close cover securely. Place pressure regulator on vent pipe and COOK 40-50 MINUTES at 15 pounds pressure. Let pressure drop of its own accord.

20-24 servings.

LAMB STEW

- | | |
|-------------------------------------------------------|-------------------------------------------|
| 6 pounds breast of lamb, cut into 1-inch cubes | 8 onions , diced |
| 3 tablespoons vegetable oil | 3 green peppers , diced |
| Salt and pepper | 2 tablespoons Worcestershire sauce |
| 12 carrots , cut in halves | 4 cups water |

Heat oil in canner over medium heat. Brown lamb well on all sides. Season with salt and pepper. Add carrots, onions, green peppers, Worcestershire sauce, and water. Close cover securely. Place pressure regulator on vent pipe and COOK 8 MINUTES at 15 pounds pressure. Let pressure drop of its own accord.

12 servings.

PRESSURE COOKING POULTRY

Poultry recipes are cooked at 15 pounds pressure. Try the following suggested recipes and enjoy tasty poultry in a variety of sauces. Or, prepare your own favorite poultry dishes. When you wish to seal the natural juices into the poultry, sear to a crispy brown prior to pressure cooking. When it is desirable to intermingle food flavors during cooking, it is best not to brown poultry; just cook it in the liquid indicated in the recipe.

DO NOT FILL CANNER OVER $\frac{2}{3}$ FULL!

The following recipes are intended for pressure cooking and should not be canned.

COOKING RECIPES: POULTRY

CHICKEN IMPERIAL

- | | |
|-------------------------------------------------------|-----------------------------------|
| 9 pounds chicken, cut into serving pieces | 1 cup slivered almonds |
| 3 tablespoons vegetable oil | 4 (4-ounce) cans mushrooms |
| 1 teaspoon salt, or as desired | 2 cups chicken broth |
| $\frac{1}{2}$ teaspoon black pepper | 1 cup white wine |
| $\frac{1}{2}$ cup minced onion | |

Heat oil in canner over medium heat. Brown chicken. Season with salt and pepper. Add onion, almonds, mushrooms with liquid, chicken broth, and wine. Close cover securely. Place pressure regulator on vent pipe and COOK 10 MINUTES at 15 pounds pressure. Let pressure drop of its own accord. Remove chicken from canner, thicken gravy. If desired, serve chicken on bed of hot rice, top with gravy and toasted almonds.

15-18 servings.

BRAISED WHOLE CHICKEN

- | | |
|------------------------------------|------------------------|
| 1 3- to 5- pound chicken | Salt and pepper |
| 3 tablespoons vegetable oil | 3 cups water |

Heat oil in canner over medium heat and brown chicken on all sides. Season with salt and pepper. Remove chicken. Pour water into canner. Place cooking rack and chicken in canner. Close cover securely. Place pressure regulator on vent pipe and COOK 10 MINUTES at 15 pounds pressure. Let pressure drop of its own accord.

15-18 servings.

CHICKEN MARENGO

- | | |
|-----------------------------------------|-----------------------------------|
| 9 pounds chicken, quartered | 1 pound mushrooms, sliced |
| 1 tablespoon coarse black pepper | 2 (28-ounce) cans tomatoes |
| 1 cup flour | 2 cloves garlic, minced |
| 1 teaspoon salt, or as desired | 2 cups dry white wine |
| 3 tablespoons vegetable oil | |

Rub chicken with pepper. Dredge in flour and season with salt. Heat oil in canner over medium heat. Brown chicken. Add mushrooms, tomatoes, garlic, and wine. Close cover securely. Place pressure regulator on vent pipe and COOK 10 MINUTES at 15 pounds pressure. Let pressure drop of its own accord. Remove chicken from canner. Thicken cooking liquid, if desired.

15-18 servings.

CORNISH HENS IN WHITE WINE

8 cornish hens
3 tablespoons vegetable oil
1 teaspoon salt
½ teaspoon black pepper

2 cups white cooking wine
2 teaspoons instant chicken bouillon
1 tablespoon chopped parsley
1 teaspoon dried thyme

Heat oil in canner over medium heat and brown hens. Season with salt and pepper. Combine cooking wine, bouillon, parsley, and thyme and pour over hens. Close cover securely. Place pressure regulator on vent pipe and COOK 8 MINUTES at 15 pounds pressure. Let pressure drop of its own accord.

8-12 servings.

HUNTER'S TURKEY

9 pounds turkey, cut into serving pieces
3 tablespoons vegetable oil
Salt and pepper
3 onions, chopped
3 (8-ounce) cans tomato sauce

3 cups chicken broth
1 tablespoon Worcestershire sauce
2 bay leaves
1 teaspoon dried thyme
1 teaspoon dried marjoram

Heat oil in canner over medium heat and brown turkey. Season with salt and pepper. Add onion, tomato sauce, chicken broth, Worcestershire sauce, bay leaves, thyme, and marjoram. Close cover securely. Place pressure regulator on vent pipe and COOK 10 MINUTES at 15 pounds pressure. Let pressure drop of its own accord.

15-18 servings.

PRESSURE COOKING DRY BEANS AND PEAS

The pressure canner is ideal for preparing dry beans and peas quickly. However, dry beans and peas have a tendency to froth and foam during cooking, which could cause the vent pipe to become blocked.

Therefore, it is necessary to follow these instructions when pressure cooking dry beans and peas:

1. Never fill the canner over the ½ full line (this includes beans, ingredients, and water).
2. Add 1 tablespoon vegetable oil for cooking.
3. Allow pressure to drop of its own accord.

Soaking Beans and Peas: Soaking before pressure cooking is strongly recommended for most dry beans and peas. Black-eyed peas, lentils, and large lima beans do not require soaking. Benefits of soaking include eliminating some of the water-soluble starches that produce gas and create froth and foam during cooking, decreasing the cooking time, and producing beans and peas that are more evenly cooked.

Soak beans and peas using one of these methods:

Traditional Method: Clean and rinse beans; cover with three times as much water as beans. Soak 4 to 8 hours. For firmer beans, soak 4 hours. Drain.

Quick Method: Clean and rinse beans; cover with three times as much water as beans. Bring beans to a boil and boil for 2 minutes. Remove from heat, cover, and let stand for 1 hours. Drain.

Cooking Beans and Peas: After soaking, rinse beans and remove any loose skins. Place beans in pressure canner. Add fresh water to just cover the beans and add 1 tablespoon vegetable oil. Close cover securely. Place pressure regulator on vent pipe and cook at 15 pounds pressure according to the times in the chart on page 32. For more firm beans for salads and side dishes and when cooking less than 2 cups of beans or peas, use the shorter time. For soup and stew, use the longer time.

After cooking is complete, allow pressure to drop of its own accord.

DO NOT FILL CANNER OVER ½ FULL!

DRY BEANS AND PEAS TIMETABLE

Soak beans and peas, except lentils and black-eyed peas, according to the information on page 31. Black-eyed peas, lentils, and large lima beans do not require soaking. **Add 1 tablespoon vegetable oil to cooking liquid. DO NOT COOK SPLIT PEAS.**

DO NOT FILL CANNER OVER ½ FULL!

BEANS AND PEAS	COOKING TIME
Adzuki	1–3 minutes
Anasazi	1–3 minutes
Black Beans	2–4 minutes
Black-Eyed Peas	2–4* minutes
+Chickpeas (garbanzo)	7–10 minutes
Great Northern Beans	2–5 minutes
Kidney Beans	1–3 minutes
Lentils (brown, green)	3–5* minutes

BEANS AND PEAS	COOKING TIME
+Lima Beans (large)	0* minutes
+Lima Beans (baby)	1–3 minutes
Navy Beans (pea)	1–3 minutes
Peas (whole yellow, green)	6–9 minutes
Pinto Beans	3–6 minutes
Red Beans	3–6 minutes
Soy Beans (beige)	8–11 minutes

+Add ½ to 1 teaspoon salt to soaking and cooking water to keep bean skins intact.

*Cooking time is for unsoaked beans.

The following recipes are intended for pressure cooking and should not be canned.

COOKING RECIPES: SOUP AND STOCK

BOSTON BAKED BEANS

6 cups dried beans
1 pound salt pork or bacon, diced
½ cup packed brown sugar
2 teaspoons dry mustard
1 cup molasses

1 cup ketchup
4 onions, diced
Water
 * * * * *
Salt, as desired

Soak beans according to instructions on page 31. Drain and discard liquid. Heat canner and sear salt pork or bacon. Remove excess drippings. Add beans, brown sugar, dry mustard, molasses, ketchup, onions, and enough water to well cover beans. **Do not fill canner over ½ full.** Close cover securely. Place pressure regulator on vent pipe and COOK 35 MINUTES at 15 pounds pressure. Let pressure drop of its own accord. Season to taste with salt.

12-15 servings.

SAVORY WHITE BEANS

4 cups navy beans
6 cups chicken broth
2 cups chopped onion
2 cups sliced carrots
1½ tablespoons minced garlic
2 tablespoons vegetable oil

2 small bay leaves
¾ teaspoon dried thyme
½ teaspoon dried rosemary
½ teaspoon black pepper
 * * * * *
Salt, as desired

Soak beans according to instructions on page 31. Drain and discard liquid. Add beans, chicken broth, onion, carrots, garlic, vegetable oil, bay leaves, thyme, rosemary, and pepper to canner. Close cover securely. Place pressure regulator on vent pipe and COOK 2 MINUTES at 15 pounds pressure. Let pressure drop of its own accord. Season to taste with salt.

12-15 servings.

LIMA BEANS WITH BACON

6 cups dried lima beans
1 pound bacon, diced
Water

* * * * *
Salt, as desired

Soak beans according to instructions on page 31. Drain and discard liquid. Heat canner and brown bacon. Add beans and enough water to well cover beans. **Do not fill canner over ½ full.** Close cover securely. Place pressure regulator on vent pipe and COOK 3 MINUTES at 15 pounds pressure. Let pressure drop of its own accord. Season to taste with salt.

12-15 servings.

PRESSURE COOKING SOUP AND STOCK

Make homemade soup the easy way in your canner. If you wish to prepare your family's favorite soup, use the following recipes as guides. Soup recipes are cooked at 15 pounds pressure.

If adding dry beans and peas, they must first be soaked according to the directions on page 31. **Do not pressure cook soup containing barley, rice, pasta, split peas, grains, dry beans and peas which are not listed in the chart on page 32, and dried soup mixes** because they have a tendency to foam, froth, and sputter and could block the vent pipe.

Cooked barley, rice, grains, pasta, dry beans and peas which are not listed in the chart on page 32, and dried soup mixes should be added to the soup after pressure cooking.

The canner quickly transfers natural flavor and nutrients from the meat into the broth. Prepare either the Brown Beef Stock or the Chicken Stock according to the recipe. Remove the pieces of meat. If desired, cut into small pieces and use in soup recipes. Strain through several layers of cheesecloth. Once the stock is prepared, serve it as a consommé or use it to prepare delicious soups.

DO NOT FILL CANNER OVER ½ FULL!

The following recipes are intended for pressure cooking and should not be canned.

COOKING RECIPES: SOUP AND STOCK

CLAM CHOWDER

1 pound salt pork, cubed	Salt and pepper
6 cups water	* * * * *
12 cups diced potatoes	4 quarts clams, minced
4 onions, minced	4 quarts hot milk
4 cups corn	½ cup butter

Heat canner and brown salt pork. Add water, potatoes, onions, corn, salt, and pepper. Close cover securely. Place pressure regulator on vent pipe and COOK 5 MINUTES at 15 pounds pressure. Let pressure drop of its own accord. Add clams and boil, without cover, for 2 minutes. (Additional cooking will toughen clams.) Add milk and butter.

16 servings.

VEGETABLE SOUP

4 pounds soup meat	4 cups canned or fresh tomatoes
2 quarts water	2 cups frozen lima beans
6 carrots, diced	1 cup diced celery
6 potatoes, diced	1 tablespoon salt, or as desired
4 onions, sliced	

Place meat, water, carrots, potatoes, onions, tomatoes, beans, celery, and salt in canner. Close cover securely. Place pressure regulator on vent pipe and COOK 20 MINUTES at 15 pounds pressure. Let pressure drop of its own accord.

12-15 servings.

NAVY BEAN SOUP

4 cups dried navy beans	2 cups tomato sauce
3 pounds ham bone or shank	2 whole cloves
2 onions, chopped	3 quarts water
4 carrots, sliced	* * * * *
4 ribs celery, sliced	Salt and pepper, as desired
¼ cup minced green pepper	

Soak beans according to instructions on page 31. Drain and discard liquid. Place beans, ham bone, onions, carrots, celery, green pepper, tomato sauce, cloves, and water in canner. Close cover securely. Place pressure regulator on vent pipe and COOK 30 MINUTES at 15 pounds pressure. Let pressure drop of its own accord. Season to taste with salt and pepper.

12-15 servings.

CHICKEN STOCK

4 pounds chicken, cut into serving pieces
4 quarts water
1 cup diced celery

1 cup diced carrots
2 onions, chopped
1 tablespoon salt, or as desired

Place chicken, water, celery, carrots, onions, and salt in canner. Close cover securely. Place pressure regulator on vent pipe and COOK 10 MINUTES at 15 pounds pressure. Let pressure drop of its own accord. Strain stock.

12-15 servings.

BROWN BEEF STOCK

4 pounds beef, cubed
3 tablespoons vegetable oil
3 quarts water
1 cup sliced onion
1 cup diced carrots

1 cup chopped celery
1 cup diced turnips
2 tablespoons dried parsley
1 bay leaf
1 tablespoon salt, or as desired

Heat oil in canner over medium heat and brown beef. Add water, onion, carrots, celery, turnips, parsley, bay leaves, and salt. Close cover securely. Place pressure regulator on vent pipe and COOK 20 MINUTES at 15 pounds pressure. Let pressure drop of its own accord. Strain stock.

12-15 servings.

PRESSURE COOKING DESSERTS

Your canner offers a shortened method for preparing steamed breads and desserts. Actually, the cooking time can be counted in minutes instead of hours. You will find, too, that your canner is easier to use than the ordinary steamer because its pressure regulator acts as a means of measurement to assure constant heat to produce uniform, even-textured products. Consult specific recipes for cooking pressure.

Best results are obtained when 1- to 1½-quart molds are used. Any type of mold is satisfactory (metal, glass, earthenware, tin food cans). Remember, never fill molds over ⅔ full; this extra top-space is to allow ample space for rising. Cover molds securely with aluminum foil shaped to the sides of the mold. If the recipe calls for a steaming period before pressure cooking, pour 3 quarts of water into the canner.

Adjust heat to allow a moderate flow of steam from the vent pipe.

DO NOT FILL CANNER OVER ⅔ FULL!

The following recipes are intended for pressure cooking and should not be canned.

COOKING RECIPES: DESSERTS

BROWN BETTY

2 cups dried bread crumbs
½ cup sugar
1 teaspoon ground cinnamon
1 lemon, juice and rind

9 apples, peeled, cored, and sliced
½ cup melted butter
1 quart water

Combine crumbs, sugar, cinnamon, lemon juice, and grated rind. Place alternate layers of apples and crumb mixture in buttered bowl that may be set loosely in canner. Pour melted butter over top. Cover firmly with aluminum foil. Place water, cooking rack, and bowl in canner. Close cover securely. Place pressure regulator on vent pipe and COOK 20 MINUTES at 15 pounds pressure. Let pressure drop of its own accord.

12 servings.

ENGLISH PLUM PUDDING

1 cup sifted all-purpose flour
1 teaspoon baking powder
½ teaspoon salt
½ teaspoon ground allspice
½ teaspoon ground cinnamon
½ teaspoon ground nutmeg
¼ teaspoon ground cloves
½ cup raisins

½ cup currants
½ cup chopped nuts
1 egg
½ cup sugar
½ cup ground suet
½ cup milk
3 quarts water

Sift flour with baking powder, salt, allspice, cinnamon, nutmeg, and cloves. Add raisins, currants, and nuts. Beat egg; add sugar, suet, and milk. Combine liquid and dry ingredients; mix well. Pour into buttered 1-quart mold. Cover mold firmly with aluminum foil. Place water, cooking rack, and mold in canner. Close cover securely. Allow steam to flow from vent pipe 20 minutes. Place pressure regulator on vent pipe and COOK 50 MINUTES at 10 pounds pressure. Let pressure drop of its own accord.

BREAD PUDDING

4 cups cubed dry bread
4 cups hot milk
½ teaspoon salt
1 cup packed brown sugar
1 teaspoon ground cinnamon
2 tablespoons butter

1 cup raisins
1 cup chopped nuts
4 eggs
1 teaspoon vanilla
1 quart water

Combine bread, hot milk, salt, brown sugar, cinnamon, butter, raisins, nuts, eggs, and vanilla. Turn into a buttered bowl that may be set loosely in canner. Cover bowl firmly with aluminum foil. Place water, cooking rack, and bowl in canner. Close cover securely. Place pressure regulator on vent pipe and COOK 20 MINUTES at 15 pounds pressure. Let pressure drop of its own accord.

12 servings.

BROWN BREAD

2 cups graham flour
2 cups corn meal
2 cups rye meal
2 teaspoons salt
2 teaspoons baking soda

1½ cups light molasses
4 cups milk, sweet or sour
2 cups raisins
3 quarts water

Mix flour, corn meal, rye meal, salt, and baking soda. Add molasses, milk, and raisins. Beat well. Pour into 6 buttered molds (pint size). Cover firmly with aluminum foil. Place water, cooking rack, and molds in canner. Close cover securely. Allow steam to flow from vent pipe 20 minutes. Place pressure regulator on vent pipe and COOK 25 MINUTES at 10 pounds pressure. Let pressure drop of its own accord.

RECIPE INDEX

PRESSURE CANNING RECIPES

FISH AND SEAFOOD	20
Clams	20
Fish	20
Tuna	21
FRUITS	10
Apples	11
Applesauce	11
Apricots	11
Berries	11
Cherries	12
Nectarines and Peaches	12
Pears	12
Plums	13
Rhubarb	13

MEAT, GAME, AND POULTRY . .	19
Cut-Up Meat	19
Ground Meat	19
Poultry	20
Rabbit	20
STOCK AND SOUP	21
Beef Stock	21
Chicken Stock	21
Soup	21
TOMATOES AND TOMATO PRODUCTS	13
Tomatoes (without added liquid) .	14
Tomatoes (packed in water)	14
Tomato Juice	14
Tomato Sauce	14
Salsa	14
Spaghetti Sauce without Meat . . .	15
Spaghetti Sauce with Meat	15

VEGETABLES	15
Asparagus	16
Beans or Peas—Dry	16
Beans—Fresh Lima, Butter, Pinto, or Soy	16
Beans—Green, Wax, Italian	16
Beets	17
Carrots	17
Corn—Whole Kernel	17
Greens	17
Mushrooms	17
Okra	17
Peas—Green	18
Peppers—Hot or Sweet	18
Potatoes—Sweet	18
Potatoes—White	18
Pumpkin and Winter Squash	18

BOILING WATER CANNING RECIPES

Apple Butter	23
Grape Jelly	23

Quick Fresh-Pack Dill Pickles . . .	22
Rhubarb Strawberry Jam	23

Tomato Salsa	23
------------------------	----

PRESSURE COOKING RECIPES

DESSERTS	34
Bread Pudding	35
Brown Betty	34
Brown Bread	35
English Plum Pudding	35
DRY BEANS AND PEAS	31
Boston Baked Beans	32
Lima Beans with Bacon	32
Savory White Beans	32
Timetable	32

MEAT	26
Beef Pot Roast	27
Beef Stew	26
Braised Beef	27
Chili con Carne	29
Corned Beef	29
Italian Beef	27
Lamb Stew	30
Meat Cabbage Rolls	29
New England Boiled Dinner	29
Pork Chops	27
Pork Hocks	29
Pork Roast	28
Short Ribs of Beef	27
Spaghetti Meat Sauce	28
Swiss Steak	28
Spareribs (barbecue)	28
Spareribs (sauerkraut)	28

POULTRY	30
Chicken, Braised Whole	30
Chicken Imperial	30
Chicken Marengo	30
Cornish Hens	31
Hunter's Turkey	31
SOUP AND STOCK	33
Brown Beef Stock	34
Chicken Stock	34
Clam Chowder	33
Navy Bean Soup	33
Vegetable Soup	33

Product Registration

IMPORTANT: Please go online and register this product within ten days of purchase. Proper registration will serve as proof of purchase in the event your original receipt becomes misplaced or lost. Registration will not affect warranty coverage, but it may expedite the processing of warranty claims. The additional information requested will help us develop new products that best meet your needs and desires. To register the product, visit www.GoPresto.com/registration or simply scan this QR code. If you do not have computer access, contact the Consumer Service Department at 1-800-877-0441 for assistance with registration.



CONSUMER SERVICE INFORMATION

If you have any questions regarding the operation of your Presto® canner or need parts for your canner, contact us by any of these methods:

- Call 1-800-877-0441 weekdays 8:00 AM to 4:00 PM (Central Time)
- Email us through our website at www.GoPresto.com
- Write: National Presto Industries, Inc.
Consumer Service Department
3925 N. Hastings Way
Eau Claire, WI 54703-3703

Inquiries will be answered promptly by telephone, email, or letter. When emailing or writing, please include a phone number and a time when you can be reached during weekdays, if possible.

When contacting the Consumer Service Department or when ordering replacement parts, please specify the model and series numbers found stamped on the side of the canner body.

Please record this information:

Model _____ Series _____ Date Purchased _____

Any maintenance required for this canner, other than that described in the “CARE AND MAINTENANCE” section of this book (pages 9 and 10), should be performed by our Factory Service Department. (**Note:** We do recommend that you call our Consumer Service Department at 1-800-877-0441 prior to sending your canner in for repair.) Be sure to indicate your full name, phone number, date of purchase, and a description of the problem when sending a canner for repair.

Send canners for repair to:

Canton Sales and Storage Company
Presto Factory Service Department
Attn: Repair
555 Matthews Drive
Canton, MS 39046-3251

The Presto Factory Service Department is equipped to service all Presto® appliances and supply genuine Presto® parts. Genuine Presto® replacement parts are manufactured to the same exacting quality standards as Presto® appliances and are engineered specifically to function properly with its appliances. Presto can only guarantee the quality and performance of genuine Presto® parts. “Look-alikes” might not be of the same quality or function in the same manner. To ensure that you are buying genuine Presto® replacement parts, look for the Presto® trademark.

Replacement parts are available at hardware stores and other retail outlets. Parts may also be ordered online at www.GoPresto.com.

Presto® Limited Warranty

(Applies only in the United States)

This quality Presto® appliance is designed and built to provide many years of satisfactory performance under normal household use. Presto pledges to the original owner that should there be any defects in material or workmanship during the first twelve (12) years after purchase, we will repair or replace it at our option. Our pledge does not apply to normal wear and tear including scratches, dulling of the polish, or staining; the repair or replacement of moving and/or perishable parts such as the sealing ring, overpressure plug, or air vent/cover lock gasket; or for any damage caused by shipping. **Outside the United States, this limited warranty does not apply.**

To obtain service under the warranty, please call our Consumer Service Department at 1-800-877-0441. If unable to resolve the problem, you will be instructed to send your Presto® appliance to the Presto Factory Service Department for a quality inspection; shipping costs will be your responsibility. When returning an appliance, please include your name, address, phone number, and the date you purchased the appliance as well as a description of the problem you are encountering with the appliance.

We want you to obtain maximum enjoyment from using this Presto® appliance and ask that you read and follow the instructions enclosed. Failure to follow instructions, damage caused by improper replacement parts, abuse, misuse (including overheating and boiling the unit dry), disassembly, alterations, or neglect will void this pledge. This warranty gives you specific legal rights, and you may also have other rights which vary from state to state. This is Presto's personal pledge to you and is being made in place of all other express warranties.

National Presto Industries, Inc.
Eau Claire, WI 54703-3703